

EUROPUMP

SERVICE AND OPERATION MANUAL EUROSTAR LPG DISPENSER

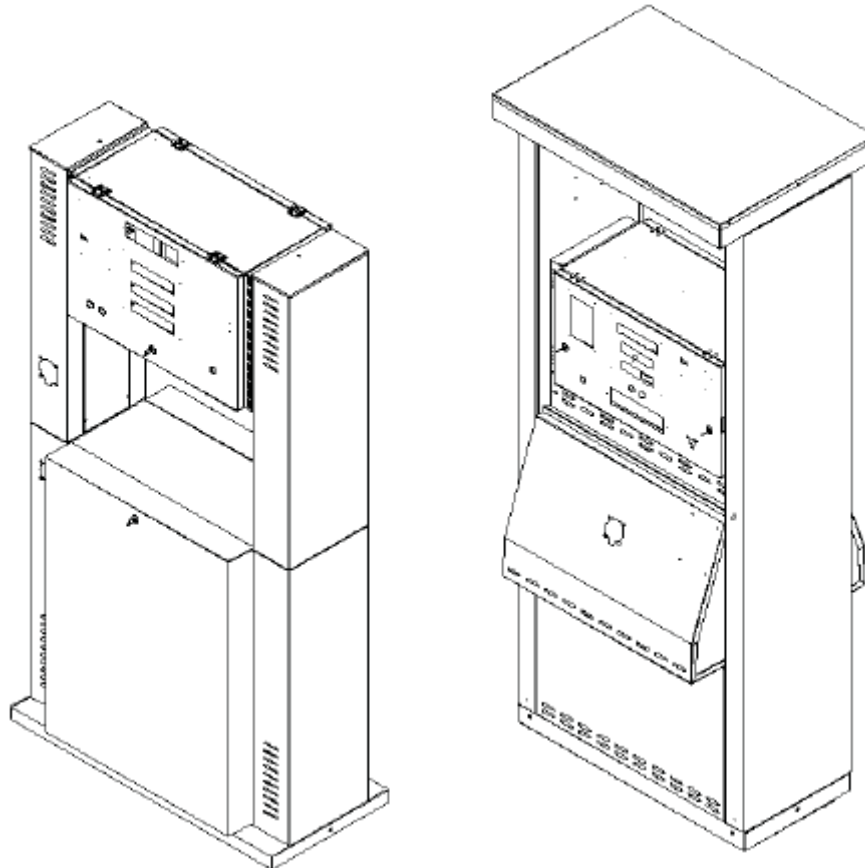

(Edition for Dispensers with PD Meters)

Document No : AT.LDKK.01
Release Date : 10.11.2005
Revision : 04
Revision Date : 30.05.2018

INDEX	Page No
1. INFORMATIONS FOR CUSTOMERS	1
1.1. Pictograms and Terms Used in the Manual	1
1.2. Important Notices	1
2. SAFETY OF DISPENSER OPERATION	2
2.1 First Aid	2
3. DENOTATION OF THE LPG DISPENSER	4
4. OVERAL VIEW AND DESCRIPTIONS OF DISPENSERS	5
5. TRANSPORTATION	11
5.1 Loading and transportation	
5.2 Unloading	
5.3 Storage of the LPG dispenser	
6. INSTALLATION AND TAKING THE LPG DISPENSER INTO SERVICE	12
6.1 Cleaning of pipes	12
6.2 Execution of Foundation	13
6.3 Shear valve / break point	13
6.4 Connection of the LPG dispenser to the suction and return line	13
6.5 LPG Dispenser Pump Switch	13
6.6 Emergency stop button	13
6.7 Gas Sensor	14
6.8 Lightning Protection	14
6.9 First Operation Of Dispenser	14
6.10 Refuelling of Cars	17
6.11 Principles of Operation and Maintenance of Break-Off Safety Valves	17
7. MAINTENANCE	18
7.1 Remarks relating operation	18
7.2 Filters	19
7.3 Greasing of rotary parts	19
7.4 Checking of hydraulic connections and electrical devices	19
7.5 Pipeline of liquefied and gaseous phases	19
7.6 Warranty and Complaints	19
8. ASSEMBLY	19
8.1 Anchoring the dispenser	19
8.2 Locking the counter	19
8.3 Mounting the columns	19
9. DISASSEMBLY	19
9.1 Opening the hydraulic housing	19
9.2 Opening of Counter Enclosure	20
9.3 Opening the columns	20
10. SERVICE MANUAL OF ELECTRONIC	21
10.1. SETTING OF PARAMETERS	22
10.2. DESCRIPTION OF PROGRAMMABLE FUNCTIONS	24
10.2.1. PUMP MENU	26
10.2.2. ADMINISTRATOR MENU	27

10.2.3.	SERVICE MENU	30
10.3.	GENERAL COMPUTER CONNECTION	37
10.4.	DESCRIPTION OF DISPLAYED ERRORS	38
11.	TECHNICAL DATA	39
12.	BREAKDOWN REPAIRS	40
13.	OVERALL DIMENSIONS	41
14.	CLASSIFICATION OF HAZARDOUS AREAS	47
15.	ELECTRICAL CONNECTION DIAGRAM	52
16.	HYDRAULIC SYSTEM DIAGRAMS	56
17.	FOUNDATION DRAWINGS	57
18.	CONTACT US	60

1. INFORMATIONS FOR CUSTOMERS

This service manual is designed for all customers and users of liquefied gas propane-butane dispensers series EUROSTAR.

As EUROPUMP INTERNATIONAL we recommend to become familiar with the present manual before proceeding to installation and use of this LPG dispenser.

1.1 Pictograms and Terms Used in the Manual



Caution



Hazardous Area for Explosion



Electrical Warning



No Smoking



Do not fire



No Cellphone usage

VERY IMPORTANT NOTICE :

EUROPUMP LPG DISPENSERS ARE ONLY MOUNTED ON OPEN AREAS !!!

This service manual and all other associated documents should be kept during the use of the LPG dispenser. In addition all other materials, supplemented during the use should also be kept.

Preserve this Service Manual and other documents for future users.

1.2 IMPORTANT NOTICES

1. EUROPUMP INTERNATIONAL shall not be liable for any damages or loss due to improper use of this Service Manual. In this manual it is described how to operate the LPG dispenser properly.
2. EUROPUMP INTERNATIONAL shall also be not liable for damages to persons and material due to failure in adherence to safety regulations contained in this manual.
3. The safety regulations contained herein are to be considered as a supplement of national regulations instead of replacement and therefore should be within the knowledge of personnel, that is servicing the LPG dispenser.
4. Before unpacking, installation or taking the LPG dispenser into service, read this Service manual thoroughly.
5. The propane-butane liquefied gas dispenser is only to be serviced by personnel, furnished with requisite authorisation according to national regulations.
6. Any repairs and modifications in design are subject to the manufacturer's explicit consent. Only parts approved by the manufacturer may be used.
7. To prevent electric shock or fire, any operation inside the LPG dispenser shall not be carried out before switching off power supply by the main power switch, that is placed in the room for the service personnel of the filling station.
8. In cases, when gas leakage is encountered, immediately push emergency stop button, switch off the LPG dispenser and the main power switch, that is placed in a room on the station. Do not cause pollution to the environment. Contact the manufacturer's Service Department.

9. Taking the LPG dispenser in service shall be conducted by the manufacturer's service or any other authorized service only. Any failure in adherence to these requirements entails the loss of warranty for the purchased product.
10. In cases, when irregular operation of the LPG dispenser is encountered, immediately contact the manufacturer.
11. No components of the housing may be removed during operation of the LPG dispenser.
12. The propane-butane liquefied gas dispenser may not be installed in explosive areas, Zone 0,1,2 defined in EN 60079-10
13. Due to its constructional features, the LPG dispenser may not be operated without roofing or in closed space and in cases of untight installation or during filling or cleaning of fuel tanks. The LPG dispenser is designed to deliver propane-butane liquefied gas.
14. In order to point out, that the LPG dispenser is designed, manufactured and described according to directives of the European Parliament, the LPG dispenser is denoted with CE mark (drawing 1).



Drq.1 CE Mark

15. The manufacturer reserves his right to carry out modifications in design, thereby taking into account the product quality not be affected.

2. SAFETY OF DISPENSERS OPERATION

Owner of the filling station is liable for its operation which shall be entrusted to the trained staff only, having relevant authorization. The operator refuels vehicle tanks by LPG professionally, checks state of the fuel dispenser and the technology in the preset time intervals, checks operation of the whole unit and maintains operating records.

The prohibit of smoking and open fire handling in the area of 10 m must be fixed on a visible places next to the fuel dispenser. The notice of necessary motor switch-off, max. volume of refueling (80%) and braking the vehicle from undesirable motion has also be placed here. From the design point of view the fuel dispensers and all components which might initiate explosion are approved by the state authorized institution - the State Testing Laboratory FTZÚ Ostrava-Radvanice, which issues the necessary certificates.

For detection of possible gas leaks relevant detectors/sensors should be installed in the dispenser area.

From the hygienic point of view the device is harmless for the operator and the owner. When operating and maintaining the device, it is advisable to protect the hands by gloves.

2.1 FIRST AID

Poisoning-gaseous LPG

When refueling, avoid LPG vapor inhalation - danger of suffocation. The injured person must be taken out of the contaminated area. Attention! Fire and explosion hazard! LPG is not poisonous, but is suffocating. In case of breathing failure carry out apply artificial breathing immediately. In case of blood circulation failure combine artificial breathing with indirect heart massage. Transfer the affected person the health facility immediately.

Frostbites-liquid LPG

In case of steep drop of overpressure to the atmospheric pressure the liquid LPG is evaporated under the temperature of -42°C. Leak of the liquid LPG may result in frostbites, when in contact with the skin. Do not rub the frostbitten parts of the body, but cover by a sterile dressing and call the doctor.

Eyes affected by LPG shall be flushed by plenty of water. Call the doctor.

Burns-fire

When burnt, cool the injury by cold water, do not lubricate, cover by a sterile dressing and call the doctor. Do not remove the dress. If the clothes are burnt - do not run, extinguish by water, blanket, by rolling about

3. DENOTATION OF THE LPG DISPENSER

Dispenser marking

MODEL	TYPE		NUMBER OF NOZZLES	ADDENDUMS	
X	V		Y	Z	
EUROSTAR	E	Economic Type	1	-SL	Slim long
	T	Tower Type	2	-SS	Slim Short
	F	Flag Type	4	-SM	Slim Multimedia
				-FL	Flag Long
				-FM	Flag Multimedia
				-ES	Eco Short
				-XL	Wide Long
				-XS	Wide Short
				-XX	Extra Wide
				-XM	Wide Multimedia
				-IM	Module without Electronic

Example :

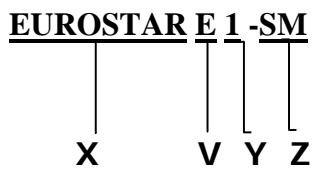

Eurostar Economic Type, One Nozzle, Slim Multimedia LPG Dispenser

4. Overall View and Descriptions of Eurostar LPG Dispensers

- Eurostar E1-SL, E2-SL

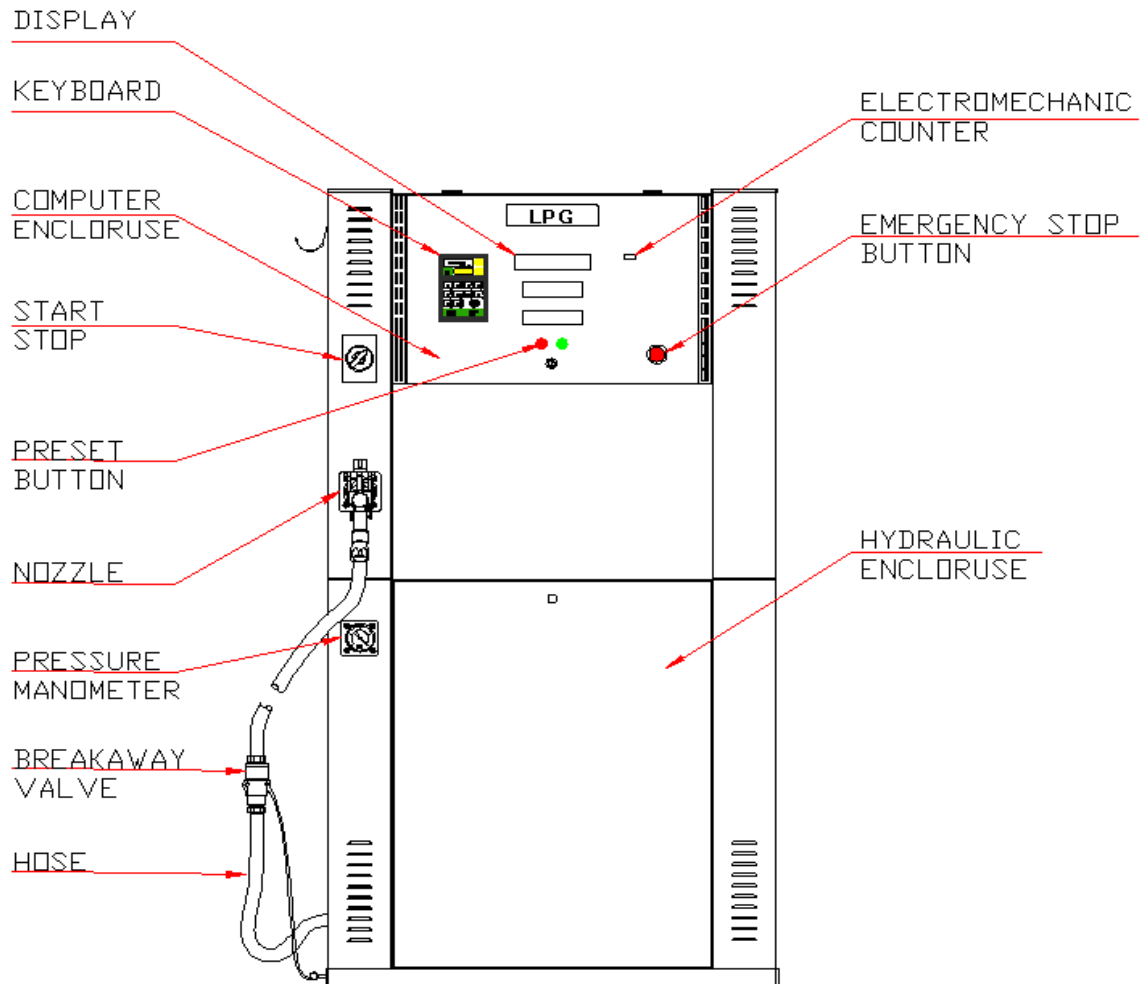

- Eurostar E1-SM, E2-SM

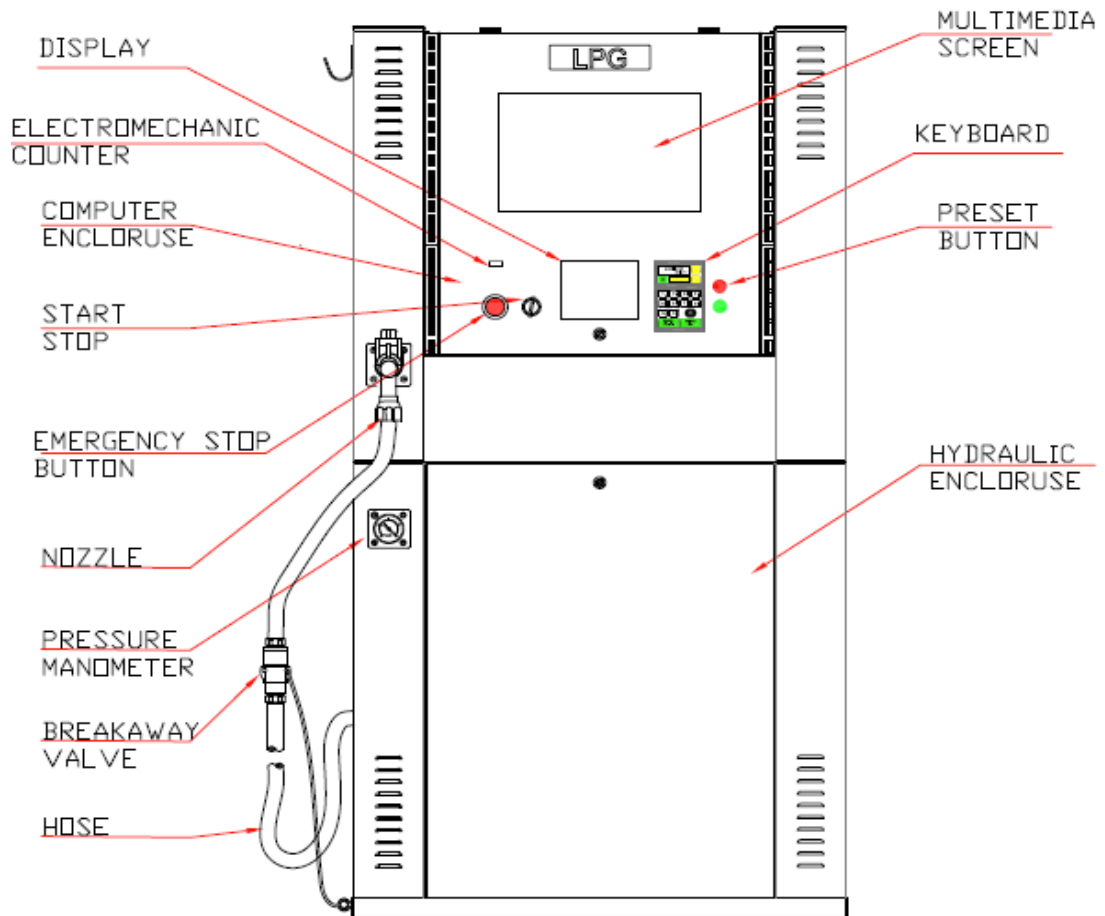

- Eurostar T1-SL, T2-SL, T1-SS, T2-SS

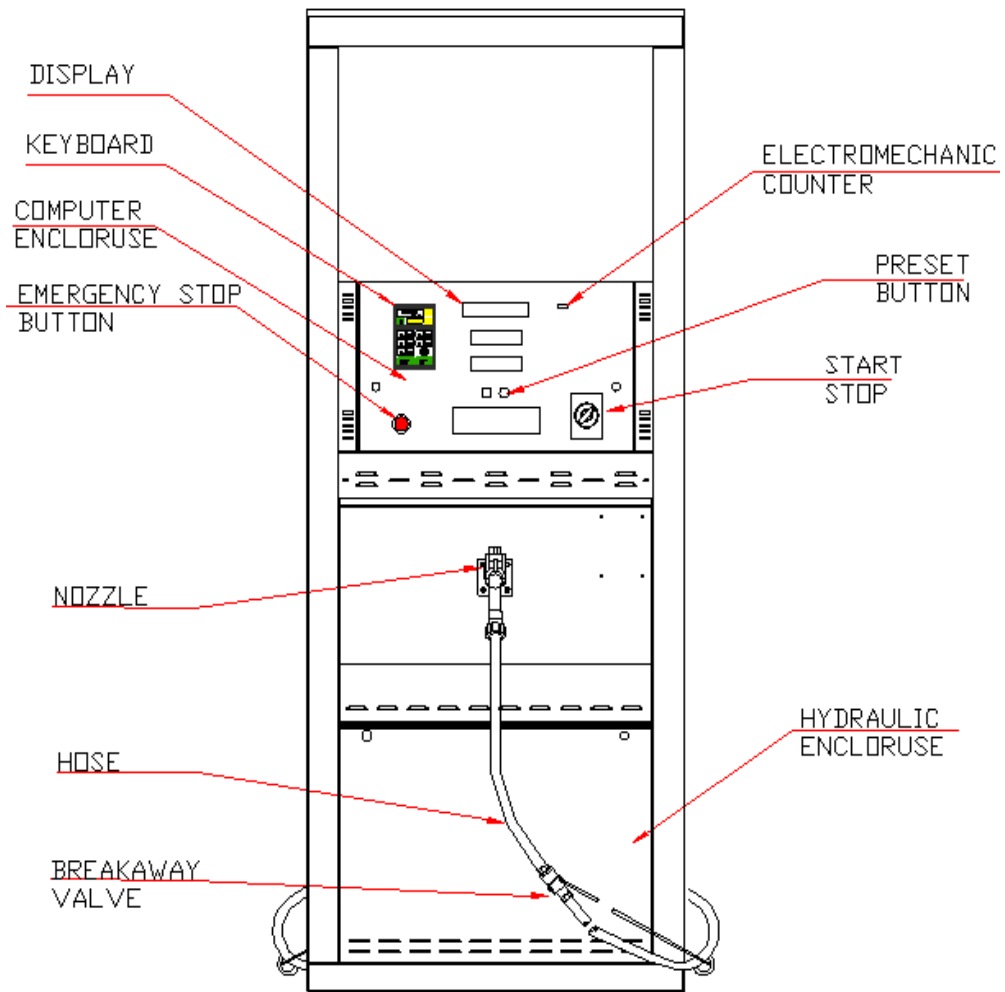

- Eurostar T1-XL,T2-XL,T4-XL

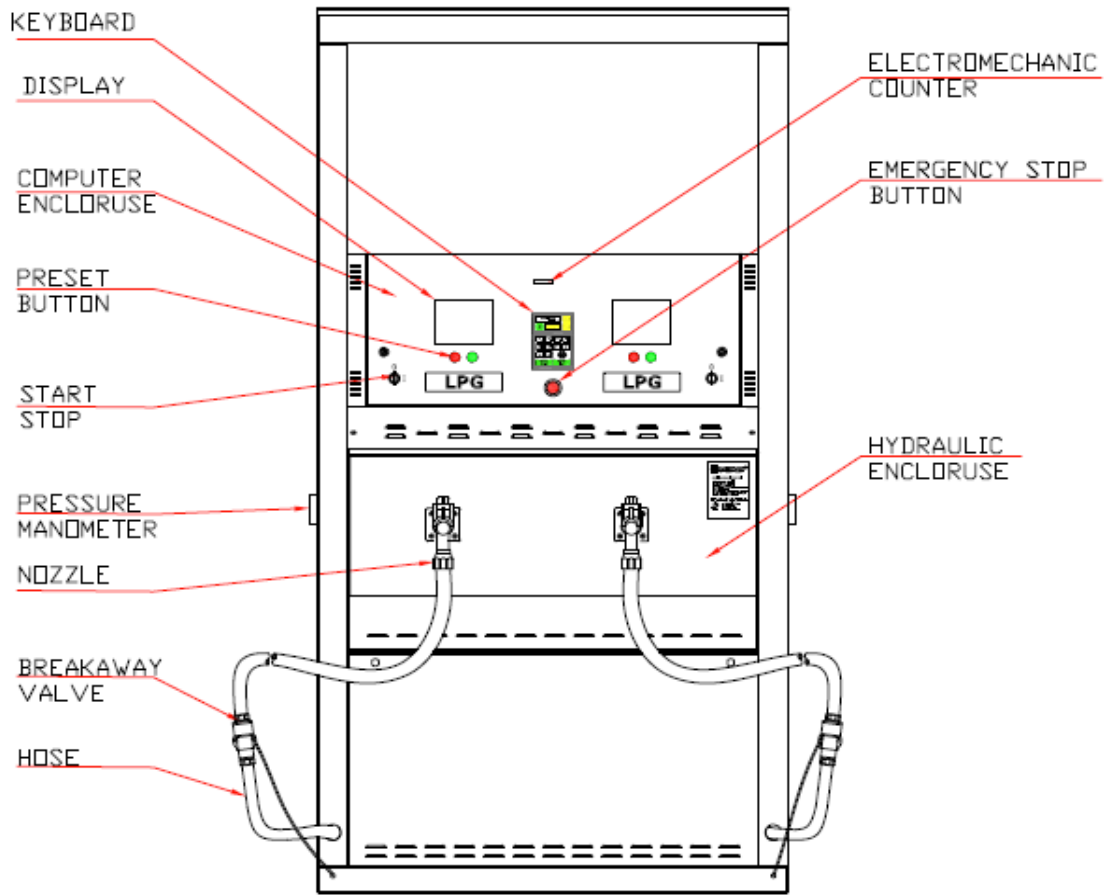

- Eurostar T1-XM+, T2-XM+, T4-XM+

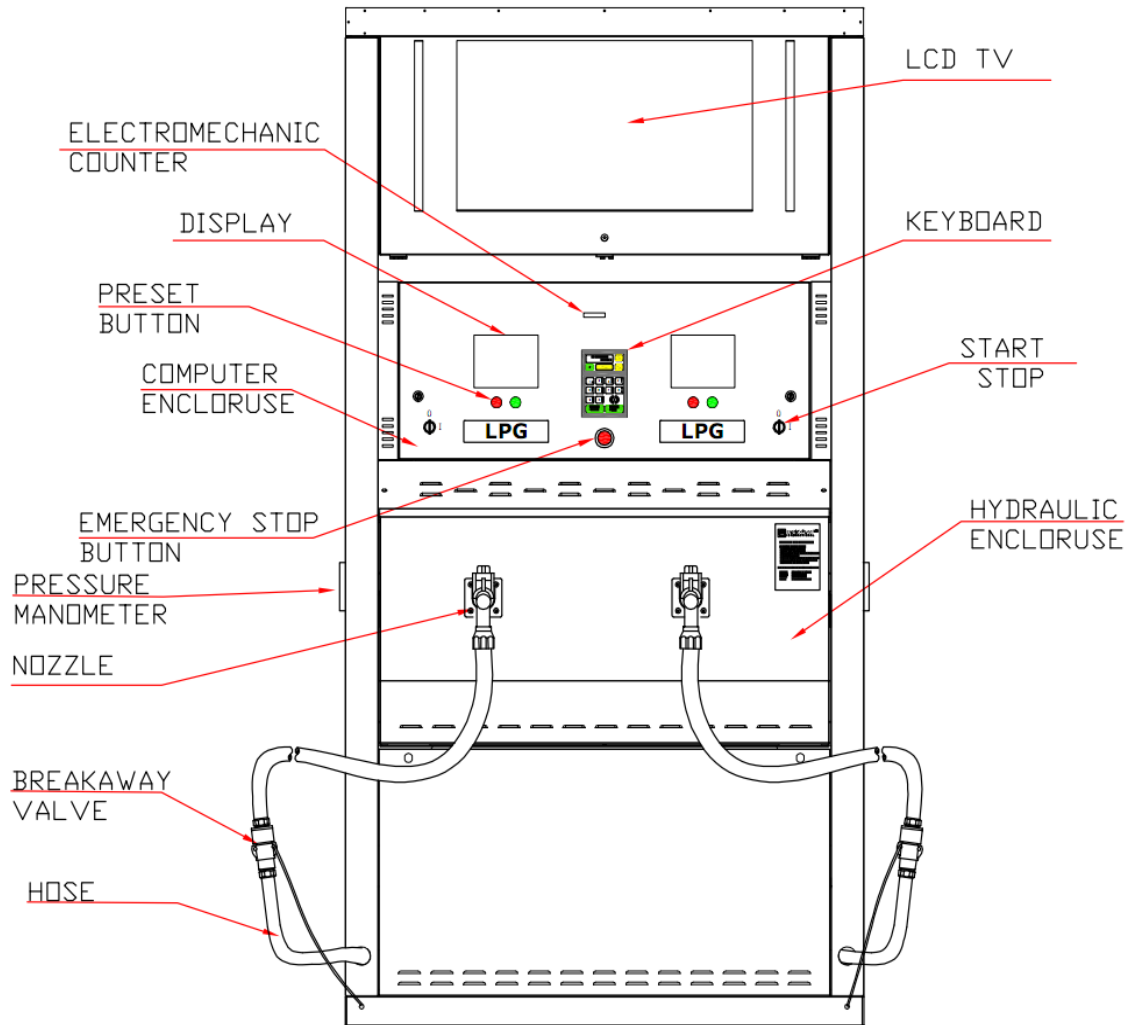

- Eurostar T1-XX,T2-XX,T4-XX

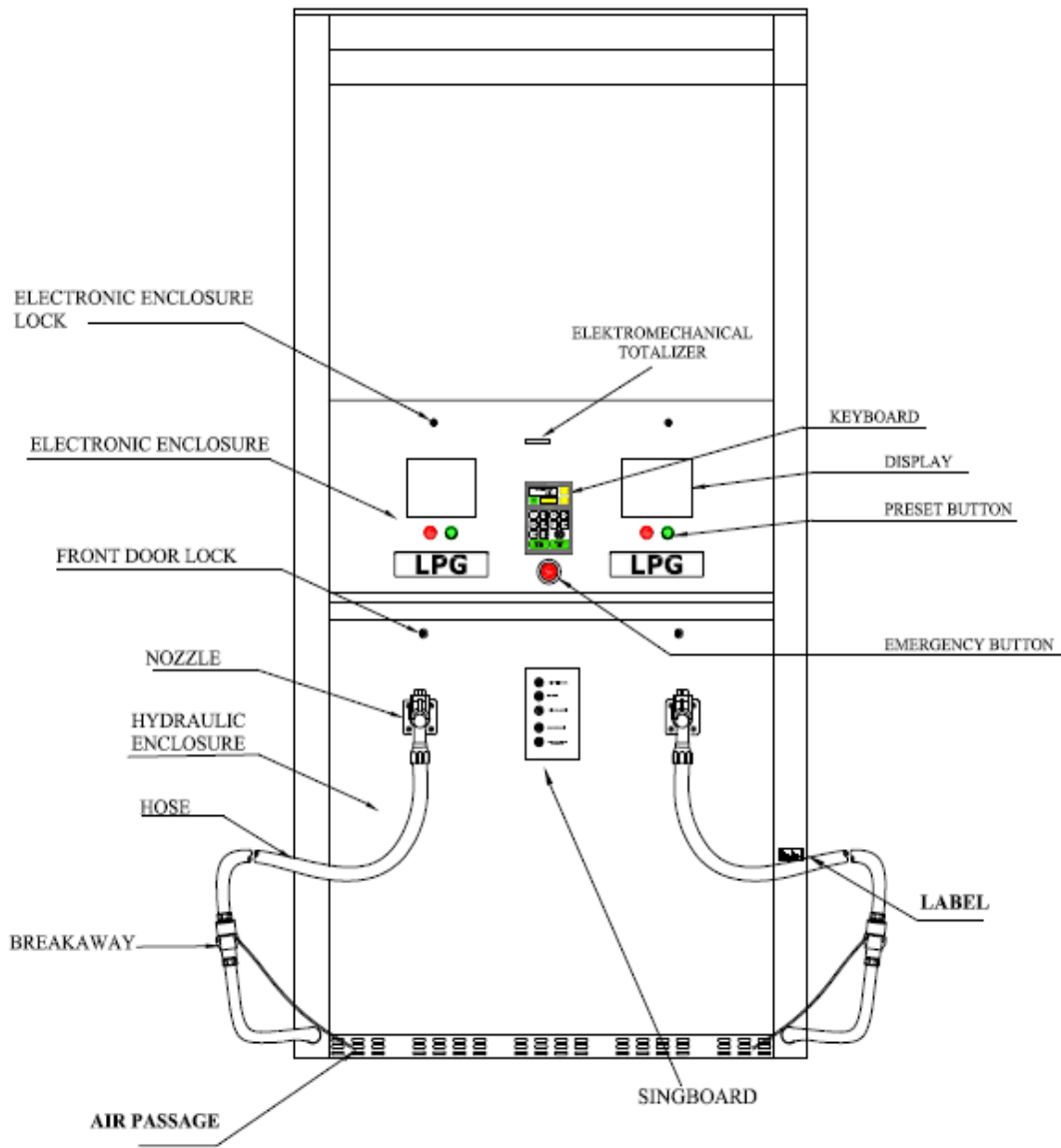

5. TRANSPORTATION

5.1 Loading and transportation

Means of transportation is determined in the contract by the customer.

Handling should be made by forklift truck. Driving the forks under the transportation palette, the LPG dispenser should be tightly secured against slippage by belts. Secure the LPG dispenser on mean of transportation against overturning and shocks, which can damage the counter and the glass elements during transportation.

Follow closely instructions on package during transportation.

The LPG dispenser should be transported only with covered means and in erect position.

5.2 Unloading

Immediately upon arrival at destination, check the LPG dispenser for any damages from transportation, for which the carrier is liable.

Unloading shall be made by driving the forklift's forks under the palette, thereby securing tightly the LPG dispenser against slippage by belts. Then the LPG dispenser should be lifted off the mean of transportation.

In order to avoid any mechanical damage to the dispenser, care should be taken during unpacking.

5.3 Storage of the LPG dispenser

Always store the LPG dispenser in dry and breezy places.

During storage, always keep the liquefied and gaseous phases, placed inside the bottom part, closed.

IMPORTANT NOTICE

Before completely assembling the LPG dispenser, remove protection layer, if provided, on the housing. Any failure to do so may cause difficulty removing the layer and give damage to the surface.

6. INSTALLATION AND TAKING THE LPG DISPENSER INTO SERVICE

Installation and taking into service the LPG dispenser shall only be made by manufacturer's technical service or an authorized technical service.

Due to the construction of the LPG dispenser, it may not operate in area without roofing or in closed space and in cases of untight installation or during filling or cleaning of fuel tanks.

RECOMMENDATIONS

1. The pulse overvoltage can take place in any line due to lightning - up to the distance of several kilometers – or due to industrial activities. The pulses arisen by lightning induction are quite enough for full destruction of the electronic unit. For this purpose the advanced countries usually apply the overvoltage protection, leading the overvoltage pulse power away into the earthing conductor, thus protecting the unit in question. Therefore the manufacturer of fuel dispensers recommends to protect the main (and/or the secondary) switchboard, feeding the fuel dispenser, electronic unit (computer, POS, etc.) and the data lines by overvoltage protection and lightning arresters.
2. In order to provide trouble-free operation of fuel dispensers it is necessary to secure the stabilized dispenser feeding by the standby source - UPS. Power supply dropouts, heavy disturbances or drop of voltage in peak hours (particularly during winter season) are very frequent phenomena in our power supply network. All phenomena as above can be eliminated by utilization of a correct standby source (UPS). There are two models of standby source available and suitable for the fuel dispenser in our market :
 - ▲ UPS of line interactive type
 - ▲ UPS of on-line typeUPS of the line-interactive type is enough for stabilization in the filling stations connected to a very stable power supply network (without any voltage drop and without any disturbances).
In other cases the ON-LINE type UPS has to be applied. Disturbances, drops of voltage or failures can result in frequent blocking of the dispensers, problems in computer/dispenser communication, failures of computers (data loss), etc.
3. For trouble-free operation of the fuel dispensers the signal cables have to be separated thoroughly from the power supply cables. Parallel connection of power and signal cables without any separation results in disturbances and undesirable parasite phenomena which may cause problems with fuel dispenser control and/or even full damage of electronic units inside the dispensers and in the kiosk. Therefore any crossing or parallel laying (in a single bundle) of the signal and power cables has to be prevented reliably. Separate "channels" (metal tubes, troughs) for power and signal cables represent a suitable solution. The manufacturer is not liable for the damages caused due to unsuitably designed cable connection.

6.1 Cleaning of pipes

Two pipes are coming from the storage tank to the dispenser. Before installing and starting the LPG dispenser, clean pipes to avoid debris of sand grain and metal chips inside the pipes. Cleaning is to be done until all impurities are removed.

Driving LPG out of the fuel dispenser and piping (e.g. during disassembly) is carried out by nitrogen or inert gas. Driving LPG out by air or oxygen is prohibited!

6.2 Execution of Foundation

Foundation is to be made according to drg.10 Lay the pipes for the liquefied line and the gaseous phase return line with diameters, as in drg.10 up to the connections of the LPG dispenser, as shown in drg.10

The EUROSTAR LPG dispenser is mounted on a frame, having four M14 fixing bolt for the four holes, diameter 16 mm in the base of the LPG dispenser, as shown in drg.10 Place the frame on the well, level and anchor in concrete foundation. Care should be taken when performing these works. Having performed these works, check once again positions of the liquefied line and the gaseous phase return line to the foundation frame and the level of the particular frame.

6.3 Shear valve / break point

The vapour return pipe shall be provided with a means to prevent the flow of LPG from the piping to the atmosphere in the event of a fracture. The liquid line for delivery of LPG shall be fitted with a means to ensure the flow is automatically stopped in the event of a fracture. This can be achieved by either a break point combined with excess flow valves, a shear valve or other suitable means.

The shear valve or break point shall be fixed rigidly to the dispenser and to the ground. The dispenser shall be provided with a means for mounting on a plinth or other foundation.

Shear valve should be used with LPG Dispensers. Installing shear valve to dispenser is responsibility of station constructors.

6.4 Connection of the LPG dispenser to the suction and return line

Before positioning the LPG dispenser on foundation (drg.5), unlock and remove frontcover of the hydraulic system. Unscrew the palette and place the dispenser on the foundation frame. Using appropriate devices secure the dispenser on the foundation frame by means of 4 M12 nuts.

The connection heights of liquefied and gaseous phases are $\frac{3}{4}$ " , as shown in drg10. In order to ensure tightness of the entire hydraulic system, all hydraulic connections must be sealed (Loctite 577 for gas sealings is recommended).

Personnel or firm to install the LPG dispenser in the filling station is required to fit globe valves on connecting nuts (stub pipes) of the liquefied and gaseous phases in the installation at the dispenser base.

The switches for operating the LPG dispenser, are placed on the LPG dispenser.

6.5 LPG Dispenser Pump Switch :

The switch is operated only manually. The switch has two positions:

1 = On , 0 = Off

In position "on", the pump is activated and delivers pressurized liquid to the dispenser. Using the switch for purposes other than intended in the manual, is prohibited.

6.6 Emergency stop button :

The emergency stop button is placed on the side wall of the LPG dispenser at a visible location "within reach". The emergency stop button switches off the entire energy supply to the Dispenser and LPG pump.



The emergency stop switches to open position and energy cuts off. Pulling the button switches off and energizes.

6.7 Gas Sensor :

For detection of possible gas leaks relevant detectors/sensors should be installed in the dispenser area.



Installing shear valve to dispenser is responsibility of station constructors.

6.8 Lightning Protection

Lightning is the visible discharge of static electricity within a cloud, between clouds, or between the earth and a cloud. Lightning is a major threat to LPG Gas Stations and systems in it - not only in rare direct strikes, but also nearby strikes radiating energy to the station. A lightning protection system does not prevent lightning from striking; it provides a means for controlling it and preventing damage by providing a low resistance path for the discharge of lightning energy.

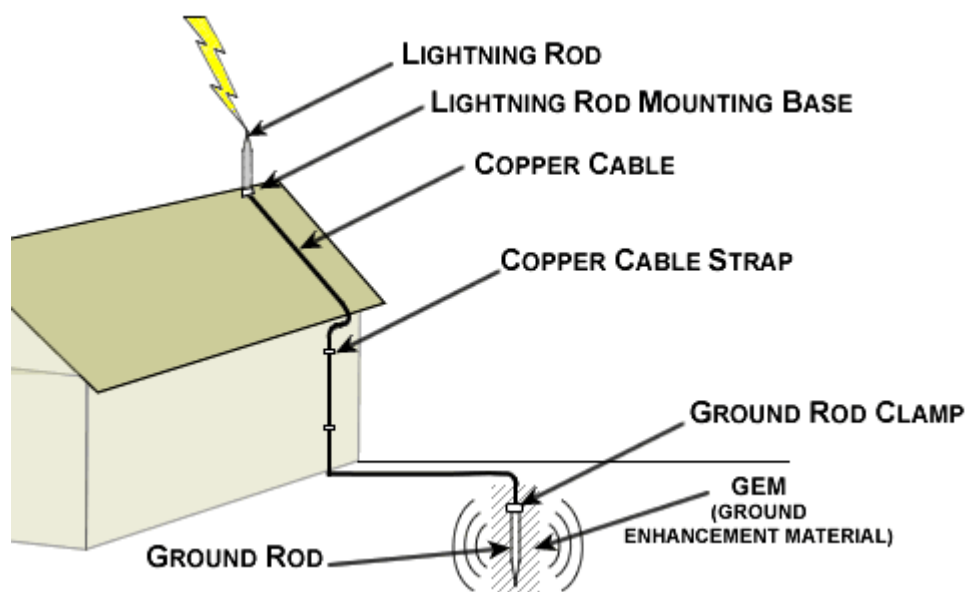

Sample station protection diagram based on station building



Lightning protection systems should be designed by skilled electrical engineers as it requires sensitive calculations and experience.

Lightning protection is responsibility of station constructors.

6.9 First Operation Of Dispenser



The propane-butane liquefied gas dispenser is to be serviced by authorized technician only.

Initial state : All valves of the installation and of the tanks in the filling station are closed.

NOTICE:

If in the present service manual reference was made to open a valve, this procedure should be made so that 10% of its operating flowrate is not exceeded by carefully and slowly shifting the lever. The valve should be maintained in this position until a consistent pressure is established and then be opened entirely.

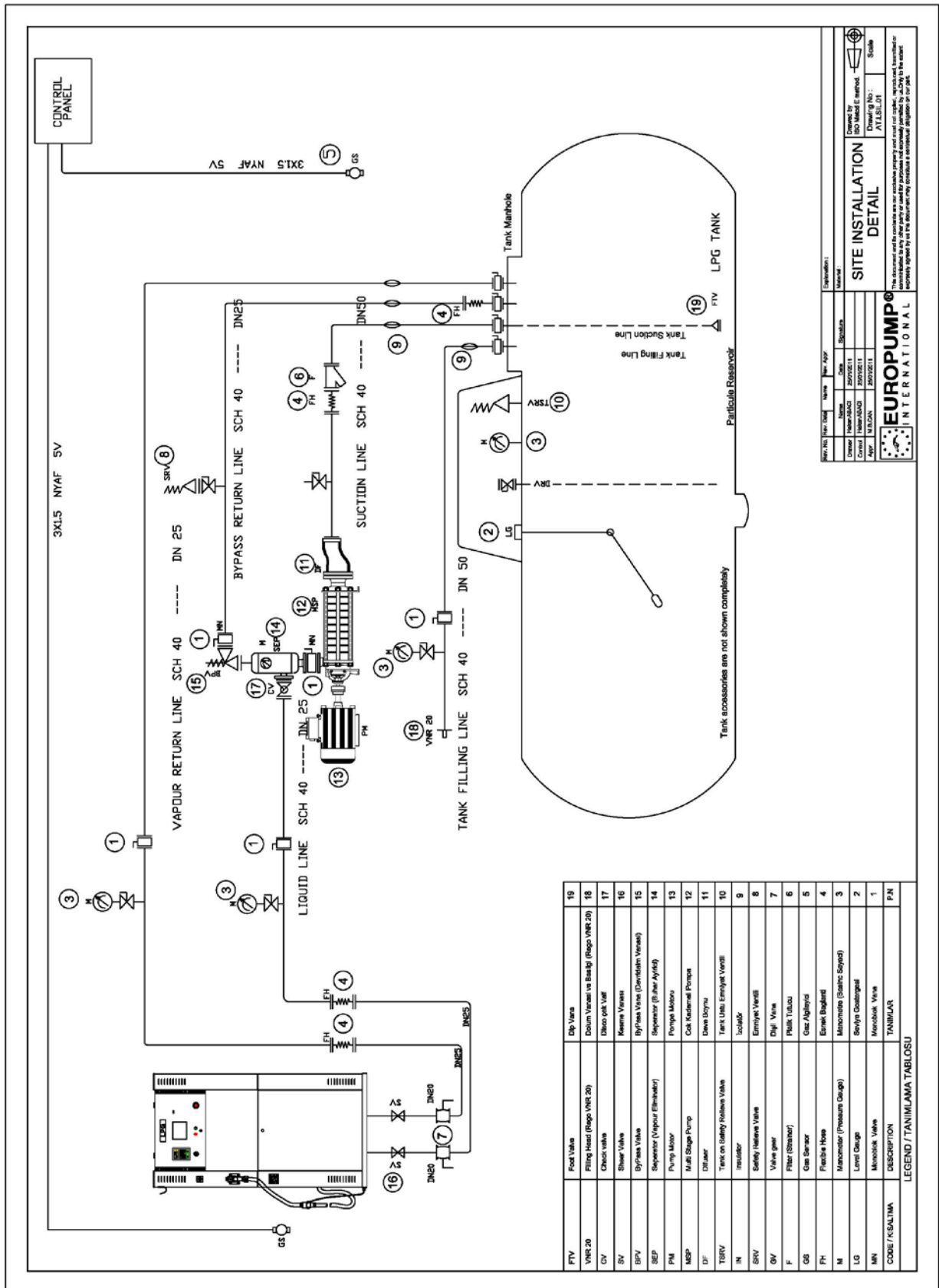

Drğ.3 Sample Station Establishment

LEGEND / TANIMLAMA TABLOSU			
P.N	TANIMLAR	DESCRIPTION	CODE / KISALTMA
1	Monoblok Vana	Monoblok Valve	MN
2	Seviye Gostergesi	Level Gauge	LG
3	Manometre (Basinc Sayaci)	Manometer (Pressure Gauge)	M
4	Esnek Baglanti	Flexible Hose	FH
5	Gaz Algilayici	Gas Sensor	GS
6	Pislik Tutucu	Filter (Strainer)	F
7	Dişli Vana	Valve gear	GV
8	Emniyet Ventili	Safety Relieve Valve	SRV
9	İzolator	Insulator	IN
10	Tank Ustu Emniyet Ventili	Tank on Safety Relieve Valve	TSRV
11	Deve Boynu	Difuser	DF
12	Cok Kademeli Pompa	Multi Stage Pump	MSP
13	Pompa Motoru	Pump Motor	PM
14	Seperator (Buhar Ayirici)	Seperator (Vapour Eliminator)	SEP
15	ByPass Vana (Devridaim Vanasi)	ByPass Valve	BPV
16	Kesme Vanası	Shear Valve	SV
17	Disco çek Valf	Check valve	CV
18	Dolum Vanasi ve Basligi (Rego VNR 20)	Filling Head (Rego VNR 20)	VNR 20
19	Dip Vana	Foot Valve	FTV

6.10 REFUELLING OF CARS

The propane-butane liquefied gas dispenser is to be serviced by personnel with appropriate authorizations only (according to domestic regulations).

Refuelling a car is performed by following operations:

- Connect the dispenser nozzle to the appropriate place of the car to be refuelled (connection to be tight and without leakage),
- Switch on the pump by setting start-stop switch of the dispenser on position 1 (switch on) (Check the manometer to indicate proper pressure of 1.0 to 1.3 MPa during pump operation);
- In case of refuelling a car brimfull (max. 80% of tank capacity), as soon as the check valve in the refuelled tank cuts off the gas flow to the tank, immediately switch off the pump.

NOTICE!

FILLING THE TANK TO ROUND UP SUMS OR DELIVERED VOLUMES AFTER ACTIVATION OF CHECK VALVE IS STRICTLY PROHIBITED.

When refuelling is finished, switch off the pump by setting start-stop switch of the dispenser on position 0/Switch off.

Disconnect the dispenser nozzle from the vehicle and hang the nozzle at the hose-hang on the dispenser.

When operation finished:

- close valves of liquefied and gaseous phases on the tank.
- cut off power supply of LPG dispenser.
- check that installation is tight.

6.11 Principles of Operation and Maintenance of Break-Off Safety Valves of Repeated Use

¾" Repeated Use Break-Off Valve

Installation, use and maintenance of the repeated break-off valve is to be in conformity with all relevant codes, rules, legal regulations. Periodical control and maintenance shall be carried out by a qualified person. Before installing, using and maintaining is performed, be sure to read and understand all instructions carefully. The final user of the gas filling station shall be familiarized with present Service Manual.

WARNING !

Contact or inhalation of liquefied propane, butane and their vapours can cause serious injuries or even death ! In order to protect human and livestock against LPG effect, it shall be diluted by carrying away outside with an air stream. To prevent any fire or explosion, LPG shall be stored in sufficient distance from open fire or any source of ignition.

LPG is heavier than air and therefore neither evaporating nor dissipating when suddenly released to still air.

Operation

The ¾" breakaway valve is specially designed to ensure safety by breaking off the refuelling procedure. If fitted at the inlet of the delivery hose, it protects against leakage at both ends. At the moment of separation only some cm³ of gas will be liberated.

Installing

Fix release arm of valve in "upstream" position.

Use M12 screw or U-screw with proper washers and nuts 3 mm diameter stainless flexible strand of appr. 450kgs tensile strength.

With appropriate connecting elements the valve shall have possibility to rotate so as to ensure collinearity of the axis and the force axis at the moment of break off.

Between stiff tubing and breakaway valve inlet a short hose shall be used. The hose length of 30-63 cm (depending on installation) shall ensure sufficient flexibility.

Fix the delivery hose with the inlet end of the break off valve.

In order to state proper and reliable operation of the break off valve of repeated use the test of breaking off shall be carried out before installation is filled with gas.

Reconnection

Before reconnection, make sure the whole inner pressure from the inlet and outlet part of the valve set of reuse is abolished. To reconnect simply push the male part into the female until the fixing balls are placed in the proper grooves of the body.

Establish a pressure in the system and in order to detect leakages carry out tightness test on joint using high solution for leakage.

NOTICE

To ensure proper operation of the break off valve, testing every 6 months is recommended (separated and greased). As source of pressure during tests the use of nitrogen or an other inert gas is recommended.

The male part of the valve must be greased at least once a 6 months.

If the valve is out of service for a longer period (e.g. seasonal operation), preserving it by spraying good quality machine oil in aerosol (e.g. WD40) or/and wrapping it against moisture is recommended.

7. MAINTENANCE

Take care of cleanness of the fuel dispenser by cleaning with a wet rag soaked with an agent, that is appropriate to that purpose.

Non-metallic surfaces of the fuel dispenser shall be cleaned with wet rag to avoid accumulation of electric charges.

Before getting started the activities, all necessary fire fighting equipment (powder extinguishers, sandbuckets, etc.) shall be held ready at the working location.

7.1 Remarks relating operation

Proper and error free operation of the fuel dispenser depends on:

- Proper connection and execution of the gas and electric installations,
- Proper servicing of the fuel dispenser (according to instruction),
- Correctly adjusted pump (the adjustment depending on operation conditions),
And besides the above
- Take care the stepped pump not to form cavitation
- Do not refuel gas cylinders
- Do not refuel vehicles with stretched delivery hose (possibility of breaking of the safety valve),
- Pay special attention to prevent the delivery hose not to get under a wheel of refuelled vehicle,
- Do not use open fire in the zone of explosive conditions
- Observe the basic rules of industrial safety and fire fighting codes.
And besides the above

7.2 Filters

In case the of decrease in flow rate and pressure, check filters and if contaminated, replace with new ones. Replacing of filters is started from protection of the dispenser by closing the liquefied and gaseous phases in the dispenser. In case of the EUROSTAR

dispenser, the filter between separator and meter is degassed by unscrewing the 4 screws M8 to fix the cover by wrench 8 mm and the screw allowing the filter cartridge to be removed by wrench 32 mm. Having replaced the filter cartridge and accurately fixed cover (of housing), slightly fill installation, observing the tightness of the entire system. In case of leakage, stop the work and eliminate the leakage. When remounting the covers, it is recommended to slightly press the screws and gaskets.

If at the end of all these works the flowrate values of the discharge valve do not conform to technical data, contact the manufacturer.

7.3 Greasing of rotary parts

All rotary parts, such as Hinges and locks shall be greased every 6 months.

7.4 Checking of hydraulic connections and electrical devices

Check tightness of electrical devices and connection elements (hydraulic connections, valves, etc.), since the fuel dispenser is exposed to vibrations during operation.

7.5 Pipeline of liquefied and gaseous phases

The tightness of nuts, connecting pipes shall be checked every three months.

Moreover, after every disassembly sealing elements shall be replaced.

7.6 Warranty and Complaints

The contractual warranty is determined - the manufacturer warrants for the supplied unit is 1 year or 1 million liters of dispensed medium as a standard. The warranty does not cover the consumables (e.g. The tubular discharge lamps). When raising possible claims, the following data have to be specified:

- Serial number and name - see the rating plate
- Precise description of fault and the circumstances under which the fault occurred.

The claim will not be acknowledged provided that damaged seals or non-permitted intervention into the unit were established. Defects and drawbacks following from incorrect operation, inspection and maintenance of the fuel dispenser or its functional assemblies are out of scope of the warranty (e.g. the problems caused by presence of water and impurities in the tank and the hydraulic system). Check for presence of water and impurities and possible cleaning is necessary in the course of operation.

8. ASSEMBLY

8.1 Anchoring the dispenser

Anchor the dispenser through 4 holes on the bottom frame and turn lock (A).

8.2 Locking the counter

Close the door of counter and turn lock (B).

8.3 Mounting the columns

Place the screws located on columns (1, 2)

9. DISASSEMBLY

! ATTENTION !

- **Before opening the housing switch off power supply.**
- **Proceed according to this Service Manual.**

9.1 Opening the hydraulic housing

Open the lock located on the upper part of the housing turning it anticlockwise by 90° (for

both sides of the dispenser separately).

Lift the housing and take out (appr. 15 cm) the gudgeons of the housing (located on top), then release the housing from the grips in the bottom lifting the housing and remove it. Now, access to the hydraulic housing is possible and hydraulic connections as well as periodical controls can be carried out.

9.2 Opening of Counter Enclosure

Before any activities are made inside the counter the power master switch (motors, lighting, counter, etc.), which is situated in the room of filling station personnel, shall be switched off.

Open the counter cover turning lock. Now, access into the housing is enabled.

9.3 Opening the columns

Remove screws located on columns (1,2). Then access to cable glands, to emergency stop and key is possible.

10. SERVICE MANUAL OF ELECTRONIC

Before any activities are made inside the counter the power master switch (motors, lighting, counter etc.), which is situated in the room of filling station personnel, shall be switched off.

The counter should indicate zero!



Delivery Total Field

Liter Field

Unit Price Field



VIEW OF DISPLAY

! ATTENTION !

1. Before the housing is opened switch off the power supply
2. Proceed according to this service manual

10.1 Setting of Parameters

The electronic register is provided with an independent external keyboard to adjust the fuel dispenser's parameters

Key guide

Guiding the use of keys and showing which keys to be used while processing an operation or making a selection.

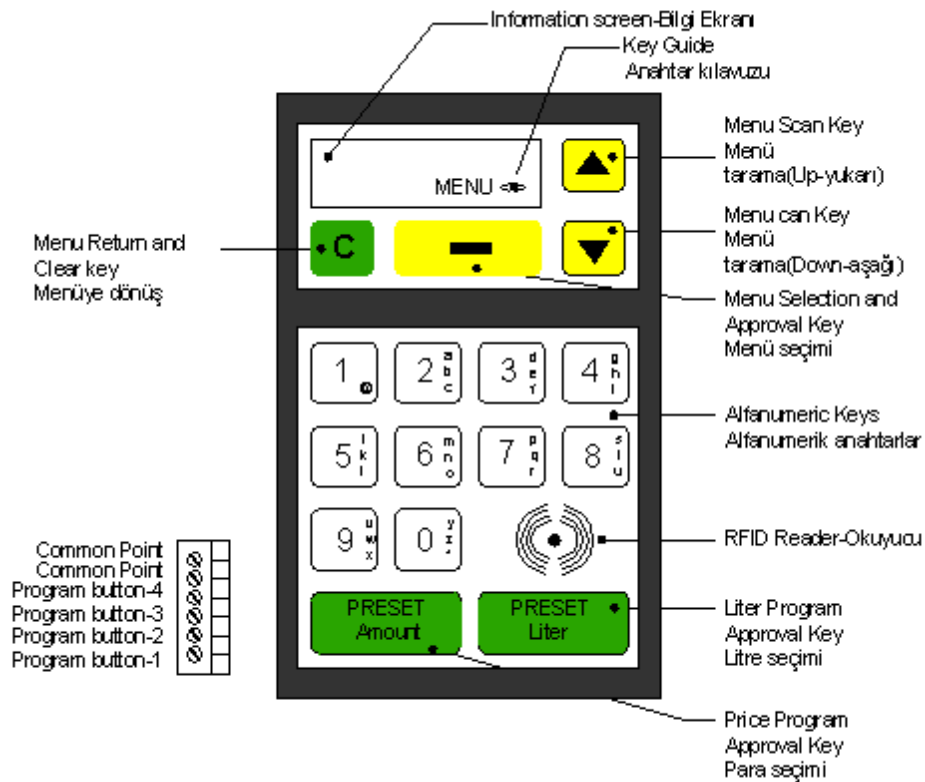

VIEW OF KEYBOARD

Meanings

- < > : Menu scan and menu return key are active.
- <N> : Menu scan, menu return and numeric key are active.
- <1> : Menu scan, menu return and 0-1 keys are active.
- <4> : Menu scan, menu return and 0-4 keys are active.
- <A> : Menu scan, menu return and alphanumeric keys are active.
- N : Numeric keys and clear key are active.

Menu selection and approval key

Used to approve selected operation by means of menu scanning keys. Facilitates operations to be done by changing the designation of this key on the screen according to operations in the menu in which is operated.

Menu return and clear key

Used to return to the menu and menu subfunctions and to clear digits or characters entered while entering data. Each time when pressed, returns to the next higher menu or function level.

Menu arrow keys

Used to scan menus and subfunctions.

Programming approval keys

Used to approve entered price and liter program.

Note : If while any menu is selected no operation is made within two minutes, the system automatically returns to default logo screen.

Abbreviations :

DT : Screen type / make

M : Motor number

V : Valve number

P : Pulser number

D : Screen number

MK : Meksan screen

S4 : S4I2C number

X : All screen types and makes

B : Preset button number

10.2 DESCRIPTION OF PROGRAMMABLE FUNCTIONS

Pump menus are subdivided in three categories.

- 1- **PUMP MENU** , This menu is used by the station personnel for basic pump procedures.
- 2- **ADMINISTRATOR MENU** , Includes procedures that can be done only by using the password of a station manager.
- 3- **SERVICE MENU**, Includes procedures, that can be done only by using password and PIN code of an authorized personnel.

PUMP MENU	PRINTER	Receipt writer functions (active, if writer selected)
	TOTAL AMOUNT	12-digit non-resettable money total
	TOTAL VOLUME	12-digit non-resettable liter total
	TOTAL SALES	12-digit non-resettable sales total
	PREVIOUS SALES-n	Display previous sales.
	FLOW RATE	Flowrate indicator (lt/min)
	HEAT INDICATOR	ATC temperature display (active, if ATC selected)
	INFORMATION	General informations
	ERROR CODES	Error codes, explanations and formation numbers
ADMINISTRATOR	SHIFT TOTALS	Resettable shift totals
	PRICE UNITS	Unit price change operations
	PREVIOUS PRICES	Previous unit prices
	DATE / TIME SETUP	Date-time settings.
	PRESET SETUP	Preset filling.
	CHANGE PASSWORD	User menu password change.
SERVICE MENU	PROTOCOLS	Serial communication protocol selections.
	PUMP NUMBER	Pump number for serial communication.
	PRODUCT DEFINITION	Product types definition (for ATC)
	DENSITY	Product density definition (for ATC)
	VALVE SETTINGS	Valve reduction and cut settings
	PUMP LIMITS	General pump limit settings
	DECIMAL POINTS	Sales screen decimal point select
	W&M CALIBRATION	Automatic flowmeter calibration
	PULSE OUTPUTS	Settings for pulse output
	C-LOOP BAUD SPEED	Current-Loop serial port speed settings
	RS232 BAUD SPEED	RS232 serial port speed settings
	PERIPHERALS	Peripheral units select
	DISPLAY TYPE	Sales screen type definitions
	PRICE/AMO RATIO	Unit price and sales price ratio select
	SERVICE REPORT	Service menu procedures report
	ERROR CODE	Report of errors ocured
	W&M EVENT REPORT	W&M calibration procedures report
	REGINONAL CODE	Country selection
	EXPULSE COUNT	Valve leakage pulses
	PUMP IDENDITY	Firm/Dispenser definition entry
NEXT INVOICE NO	Next reciept no (active, if printer selected)	
TEMPLATES	Pump setting templates	
	DIAGNOSTICS	System and peripheral unit test procedures

10.2.1. PUMP MENU

EMERGENCY STOP

Used for emergency stop while filling, if appropriate.

For operation logo screen should be visible. (If you are inside te menu, return to logo screen by menu return key)

Select nozzle number. of nozzle you want to stop, using the menu scan keys. You may exit operation by menu return key.

On display the no. of nozzle to be stopped visible.

Pressing the approval key, you can stop nozzle you selected.

PASSWORD CHANGE

Password entry procedure to enter administrator and service menu. A 4-digit password is required to enter the administrator menu. This password may also be changed through administrator menu and factory set "0000". For th service menu a 6-digit password and a 4-digit PIN-code are required, whereby PIN-code differs for every authorized personnel.

Once inside the service menu all menus are activated, whereas inside the administrator menu, pump service menus are activated.

Administrator menu entry :

For operation logo screen should be visible.

Enter the 4-digit password pressing the numeric keys. You may clear entered digits backwards in case of need.

Approve password pressing approval the key.

You may exit menu by menu return key.

Service menu entry :

For operation logo screen should be visible.

Enter the 6-digit by pressing numeric keys. Using clear key you may clear entered digits backwards, if need be.

Approve entered password by pressing approval key.

If entered 6-digit service password is correct, PIN-code will be prompted. Entering PIN-code, when approved service menu will be activated,.

You may exit the menu using menu return key.

SALES PROGRAMMING

Used for programming pump sales amounts (money and liter) prior to transaction. Preset programming procedures are done using keypad and preset buttons. Preset programming operations are carried out by using keypad or preset buttons. Inside the administrator menu preset changes for preset buttons and keypad can be carried out.

In order to cancel entered programme, carry out following procedur by entering "0".

For the operation the logo screen should appear.

Enter required amount to be programmed using numeric keys. By means of clear key you may clear backwards entered digits.

If in your presettings zeros are defined, these will be appended to the entered amount.

For Liter press "Amount", for money press "Volume" key.

If several filling points provided, nozzle number. will be prompted.

Entering the nozzle number., programmed amount will appear on the screen.

Programming with Preset Button :

For every sales point, depending on pump construction settings 1-4 units of preset buttons are available. Every time the button is pressed, the nozzle being in place, the previously defined button-1 amount will be doubled up and be visible on the sales screen. In order to cancel the programme keep button pressed during 2-3 seconds, preset will be reset to zero and the last sales screen will appear.

Notes :

- 1- For multiple product single sales point pumps, the given preset amount will be applicable to the product, of which the nozzle has been taken up first.
- 2- The entered preset amount is invalid, if it is outside the sales screen limits.
- 3- The preset operation will be cancelled after expiry of time, defined in the presettings (if no sale was made within that time)
- 4- For preset operations, valve settings in the service menu must be adjusted.
- 5- The preset buttons can effect changes depending on the number of filling points. If only one filling point provided, 4 buttons for the same filling point programmable, if simultaneously 4 filling points provided, for each filling point one button will be valid.

PRINTER MENU :

If a receipt printer is connected to system and active. Pump salesman can print out shift report or last sale receipt from this menu.

PRICE, LITER AND SALES TOTALS :

Undeletable price, liter and sales totals are accumulated totals of the sales.

If inside the menu, using scan keys; if in the logo screen, initially using approval key and then by means of menu scan keys, you may select out from "PRICE TOTALS", "LITER TOTALS" or "SALES TOTALS" whichever you wish to view.

Pressing the approval key, you may view totals you selected.

If several filling points provided, by means of menu scan keys you may view the totals of other nozzles. The digit "(1)" on the top left corner of the screen indicates the nozzle number.

By means of menu return key you may exit the menu.

PREVIOUS SALES

Indicates the money total of the last transaction.

If inside the menu using scan keys, if inside the logo screen using initially the approval key afterwards menu scan keys, select "PREVIOUS SALES" menu.

Pressing the approval key, you may view previous transaction amounts.

If several filling points provided, you may view sales of other nozzles using the menu scan keys.

By means of menu return key you may exit the menu.

FLOWRATE

Indicates the amount of last sale.

If inside the menu using scan keys, if inside the logo screen using initially the approval key afterwards menu scan keys, select "FLOWRATE INDICATOR" menu.

Pressing the approval key, you may view flowrate of the pump.

If several filling points provided, you may view flowrates of other nozzles using menu scan keys. The digit "1" in the top left corner of the screen indicates the nozzle number.

By means of menu return key you may exit the menu.

TEMPERATURE INDICATOR

If ATC feature is active, sensor temperatures and CTE (thermal expansion coefficient) values are indicated (if this feature is not selected from peripherals menu, not visible inside the menu).

If inside the menu using scan keys, if inside the logo screen using initially the approval key then afterwards menu scan keys, select "TEMPERATURE INDICATOR" menu.

Pressing the approval key, you may view sensor temperatures.

By means of menu return key you may exit the menu.

INFORMATION

Indicates meanings and no. of occurrence of error messages appearing on sales screen unit price display.

If inside the menu using scan keys, if inside the logo screen using initially the approval key afterwards menu scan keys, select "INFORMATION" menu.

Enter subfunctions pressing approval key.

Select required information using menu keys.

Indicates pump configuration setting and selected sales screen type.

Indicates Program version and date of installation.

Shows current date and hour.

Indicates mains voltage.

Indicates program CRC value.

Indicates pump operation condition.

Indicates operation intensity of the microprocessor.

Indicates passwords and PIN-codes related definitions.

By means of menu return key you may exit the menu.

ERROR CODES

Indicates meanings and no. of occurrence of error messages appearing on sales screen unit price display.

If inside the menu, using scan keys, if inside the logo screen using initially the approval key afterwards menu scan keys, select "ERROR MESSAGES" menu.

Pressing approval key, view error messages.

Using the menu scan keys, select error message you require.

By means of menu return key you may exit the menu.

10.2.2. ADMINISTRATOR MENU

SHIFT TOTALS

Deletable price totals of nozzles.

If inside the menu, using scan keys, if inside logo screen, first using administrator password, afterwards using approval key and menu scan key, select "SHIFT TOTALS" menu. Pressing the approval key you may view shift totals.

If several filling points provided, you may view shift totals of other nozzles by means of menu scan keys. The digit "[1]:" on the top left corner of the screen indicates the nozzle number.

Using menu return key you may exit menu.

PRICE UNITS

If inside menu using scan keys, if inside logo screen, first using approval key and then menu scan keys select "UNIT PRICES" menu.

Pressing the approval key you may view and change unit prices you wish to change.

If several filling points provided, you may change unit prices of other nozzles using menu scan keys. The digit "[1]:" on the top left corner of the screen indicates the nozzle number.

Using numeric keys you may change prices. Approve prices changes pressing the approval key.

Using menu return key you may exit menu or you may backwards delete starting from the last digit entered.

Note : Unit prices you changed, are visible on the screen when nozzle is activated.

PREVIOUS PRICES

From this menu you can trace previous prices with changed date and hour.

If inside the menu using scan keys, or if inside the logo screen first using approval key and then using menu scan keys select "PREVIOUS PRICES" menu.

Pressing the approval key you may view previous prices.

If several filling points are provided, by means of menu scan keys you may view prices of other nozzles. The digit "[19]" on the top left corner of the screen indicates the nozzle number. On the left bottom corner of the screen date and time of change can be seen.

Using menu return key you may exit the menu.

TIME-DATE SETUP

If inside the menu using scan keys, if inside the logo screen, first using approval key and then menu scan key select "DATE/TIME" menu.

Pressing the approval key you may view and change date and time settings.

Using numeric keys you may enter date and hour settings. Pressing the approval key toggles to the next selection. Using the menu scan keys you may select setting needed.

By means of menu scan key you may exit the menu or delete backwards starting from the last digit entered.

PRESET SETUP

Definitions for sales programming (preset) are made.

If inside the menu using scan keys, if inside the logo screen first entering the administrator password, afterwards using approval key and menu scan key select "PRESETTINGS".

Pressing the approval key you may enter subfunctions and by means of menu scan keys view and change the entered values.

- Preset button value no.1,
- Preset button value no.2,
- Preset button value no.3,
- Preset button value no.4,

If no transaction has been made within the minute after programming, made by means of keyboard, the programme will be cancelled.

Using the numeric keys you may enter settings.

You may exit the menu by means of menu return key or delete backwards starting from the last entered digit.

PASSWORD CHANGE

If inside the menu using scan keys, if inside the logo screen first entering the administrator password, then using approval key and menu scan keys select "PASSWORD CHANGE" menu. Pressing the approval key you may change administrator password.

Using the numeric keys you may enter the 4-digit administrator password and activate by means of approval key.

Using the menu return key you may exit the menu or delete backwards starting from last entered digit.

10.2.3. SERVICE MENU

PROTOCOLS

For serial communication protocol selection is made.

Order of key entry:

If inside the menu using scan keys, or if inside the logo screen first using approval key and the using menu scan keys select "PROTOCOLS" menu.

Pressing the approval key you may view selected protocol.

By means of menu scan keys you may select other protocols and pressing the approval key activate selected protocol.

Pressing approval key approve selection.

Using menu return key you may exit the menu.

Protocols:

Standalone : Operates independent from pump serial communication.

S4-dart : Extended DART protocol.

WYN-DART : Default DART protocol.

Note:

Detailed information about dart protocols is set forth in "SERIAL COMMUNICATION and DART PROTOCOL" documentation.

PUMP NUMBER

For serial communication pump number selection is made.

If inside the menu using scan keys, or if inside the logo screen first using approval key and the using menu scan keys select "PUMP NUMBER" menu.

Pressing the approval key you may view and change selected protocol.

Using the two-digit numeric keys (0-99) you may enter pump number and activate by approval key.

By means of menu scan key you may exit menu or delete backwards starting from the last entered digit.

PRODUCT TYPE

For every nozzle a product density definition is made, which is needed for ATC function.

If inside the menu using scan keys, if inside the logo screen first entering the service password and PIN-code, then using approval key and menu return key select "PRODUCT DEFINITION" menu.

Pressing the approval key you may view and change previously defined product types.

If several filling points are provided, you may change product types of other nozzles. The digit "[1]:" on the top left corner of the screen indicates the nozzle number.

Using numeric keys 1-9 you may change product type. Approve selection by pressing approval key.

By means of menu return key you may exit the menu.

PRODUCT DENSITY

For every nozzle a product density definition is made, which is needed for ATC function.

If inside the menu using scan keys, if inside the logo screen first entering the service password and PIN-code, then using approval key and menu return key select "DENSITY" menu.

Pressing the approval key you may view and change previously defined density values.

If several filling points are provided, you may change density values of other nozzles. The digit "[1]:" on the top left corner of the screen indicates the nozzle number.

Using numeric keys you may change density values. Approve selection by pressing approval key.

By means of menu return key you may exit the menu or delete backwards last entered digits.

VALVE SETUP

For preset function valve definitions are made.

If inside the menu using scan keys, if inside the logo screen first entering the service password and PIN-code, then using approval key and menu return key, select "DENSITY" menu.

Pressing the approval key you may enter subfunctions, using the menu scan keys you may view and change entered values.

For previously programmed sales (peset) value, reduction value prior to preset termination (in mm).

(if entered zero, automatically adjusts cut value)

Using numeric keys you may change valve settings. Pressing approval key approve selected change.

You may exit menu by means of menu return key or delete backwards starting from the last entered digit.

PUMP LIMITS

General pump definitions.

If inside the menu using scan keys, if inside logo screen first enter service password and PIN-code, then using approval key and menu scan keys select "PUMP LIMITS" menu.

Pressing the approval key you may enter subfunctions, using menu scan keys you may view and change entered values.

- Test screen duration when nozzle lifted. (sec)
- Stand-by time when nozzle put back. (sec)
- If within entered value (sec) after lifting nozzle no transaction is made, the engine stops.
- Last digit of Liter screen (ml x 10). After entered value screen activated.
- At flowrates higher than entered values in liters, shut-off of nozzle is retarded.
- If for LPG pumps transaction is made under the entered flowrate value in liters, after the LPG Off-Time the engine stops.
- For LPG Offset value lapse of time in seconds.
- Limit value of price field. If entered zero, limitless. (after 99999999, starting from zero)
- Liter field limit value. If entered zero, limitless. (after 9999.99 starting from zero)
- Serial communication DART protocol lapse time

Using numeric keys, you may change pump limits. Approve selected change by pressing approval key.

By means of menu return key you may exit the menu or delete backwards starting from the last entered digit.

DECIMAL POINTS

Decimal point locations of price, liter and unit price fields of sales screen are defined.

If inside the menu using scan keys, if inside logo menu first entering service password and PIN-code, then using approval key and menu scan keys, select "DECIMAL POINTS" menu. Pressing the approval key you may enter subfunctions, using menu scan keys you may view and change entered values.

- Unit price decimal point definition.
- Liter decimal point definition.
- Price decimal point definition.

Using numeric keys you may change decimal point definitions.

Approve changes pressing the approval key.

By means of menu return key you may exit the menu or delete backwards starting from the last entered digit.

W&M CALIBRATION

Automatic flowmeter calibration carried out.

If inside the menu using scan keys, if inside logo menu first entering service password and PIN-code, then using approval key and menu scan keys, select "W&M CALIBRATION" menu. Pressing the approval key you may enter sub-functions.

If several filling points provided, select using menu scan keys flowmeter to be calibrated. The digit "[1]:" on the top left corner of the screen indicates the nozzle number.

By means of menu return key you may exit menu.

PULSE OUTPUTS

If inside the menu using scan keys, if inside the logo screen first enter service password and PIN-code, then using approval key and menu scan key select "PULSE RATIOS" menu.

By means of menu scan key you may exit the menu.

C-LOOP BAUD RATE

For Current-Loop serial communication unit, baud speed is defined.

If inside the menu using scan keys, if inside the logo screen first enter service password and PIN-code, then using approval key and menu scan key select "C-LOOP BAUD SPEED" menu.

Pressing approval key you may enter subfunctions, using menu scan keys you may view and change selected values.

Having selected BAUD speed value to be changed press approval key.

By means of menu scan key you may exit the menu.

RS 232 BAUD RATE

For RS232 serial communication unit baud speed is defined.

If inside the menu using scan keys, if inside the logo screen first enter service password and PIN-code, then using approval key and menu scan key select "RS232 BAUD SPEED" menu.

Pressing approval key you may enter subfunctions, using menu scan keys you may view and change selected values.

Having selected BAUD speed value to be changed press approval key.

By means of menu scan key you may exit the menu.

PERIPHERALS

Selection of active / passive peripheral units

If inside the menu using scan keys, if inside the logo screen first enter service password and PIN-code, then using approval key and menu scan key select "PERIPHERAL UNITS" menu.

Pressing approval key you may enter subfunctions, using menu scan keys you may view and change selected values.

Pressing key 1 you may activate, pressing 0 deactivate selected unit.

Approve performed operation by pressing approval key.

By means of menu scan key you may exit the menu.

DISPLAY TYPE

Sales screen type selection.

If inside the menu using scan keys, if inside the logo screen first enter service password and PIN-code, then using approval key and menu scan key select "SALES SCREEN TYPE" menu.

Pressing approval key you may enter subfunctions, using menu scan keys you may view and change selected screen type.

Approve performed operation by pressing approval key.

By means of menu scan key you may exit the menu.

PRICE/AMO RATIO

For calculations unit price/total ratios are defined.

If inside the menu using scan keys, if inside the logo screen first enter service password and PIN-code, then using approval key and menu scan key select "UNIT/PRICE RATIO" menu.

Pressing approval key you may enter subfunctions, using menu scan keys you may view and change selected ratio.

Approve performed operation by pressing approval key.

By means of menu scan key you may exit the menu.

SERVICE LOG

Up to 250 operations of entering service menu by date, hour and PIN-code may be traced backwards.

If inside the menu using scan keys, if inside the logo screen first enter service password and PIN-code, then using approval key and menu scan key select "SERVICE REPORT" menu.

Pressing approval key enter to reports.

By means of menu scan keys you may trace records onwards and backwards. In the top line of the screen you may see date and hour, in the bottom line PIN-code.

ERROR LOG

Up to 250 operations of error codes occurred by date, hour and PIN-code may be traced backwards.

If inside the menu using scan keys, if inside the logo screen first enter service password and PIN-code, then using approval key and menu scan key select "ERROR CODE" menu.

Pressing approval key enter to reports.

By means of menu scan keys you may trace records onwards. In the top line of the screen you may see date and hour, in the bottom line nozzle number.

By means of menu scan key you may exit the menu.

W&M EVENT LOG

W&M calibration operations may be traced 250 changes backwards by date, hour and calibration value.

If inside the menu using scan keys, if inside the logo screen first enter service password and PIN-code, then using approval key and menu scan key select "W&M REPORT" menu.

Onay tuşunu kullanır Pressing approval key enter to reports.

By means of menu scan keys you may trace records onwards and backwards. In the top line of the screen you may see date and hour, in the bottom line nozzle number.

By means of menu scan key you may exit the menu.

REGINOAL CODE

If inside the menu using scan keys, if inside the logo screen first enter service password and PIN-code, then using approval key and menu scan key select "COUNTRY CODE" menu.

Pressing approval key you may enter subfunctions, using menu scan keys you may view and change selected country code values.

Approve performed operation by pressing approval key.

By means of menu scan key you may exit the menu.

EXPULSE COUNT

Shows leakage quantities while nozzle is closed.

PUMP IDENTITY

Pump identity definition number is used for printer operations, in order to specify unique pump id.

Pressing approval key you may view and change previously defined value.

Using numeric keys you may change firm definition values. Pressing approval key you may approve performed changes. By means of menu return key you may exit menu or delete backwards starting from the last entered digit.

NEXT INVOICE NO

Definition is used for printer operations to specify next receipt no.

TEMPLATES

Template definitions depending on pump type.

If inside the menu using scan keys, if inside the logo screen first enter service password and PIN-code, then using approval key and menu scan key select "TEMPLATES" menu.

Pressing approval key you may view subfunctions, using menu scan keys you may view and change selected template.

Approve performed operation by pressing approval key.

By means of menu scan key you may exit the menu.

DIAGNOSTICS

If inside the menu using scan keys, if inside the logo screen first enter service password and PIN-code, then using approval key and menu scan key select "SYSTEM CONTROL" menu.

Pressing approval key you may enter subfunctions, using menu scan keys you may select unit to be tested.

Approve performed operation by pressing approval key.

By means of menu scan key you may exit the menu.

10.3. GENERAL COMPUTER CONNECTION

S4 PRO-B

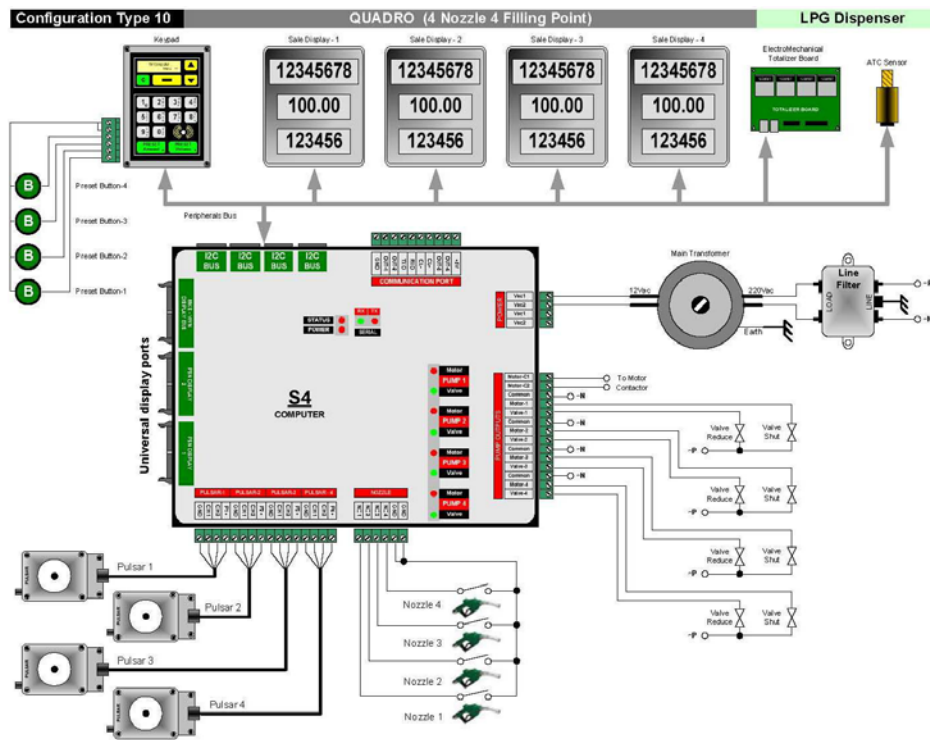

S4 PRO-C

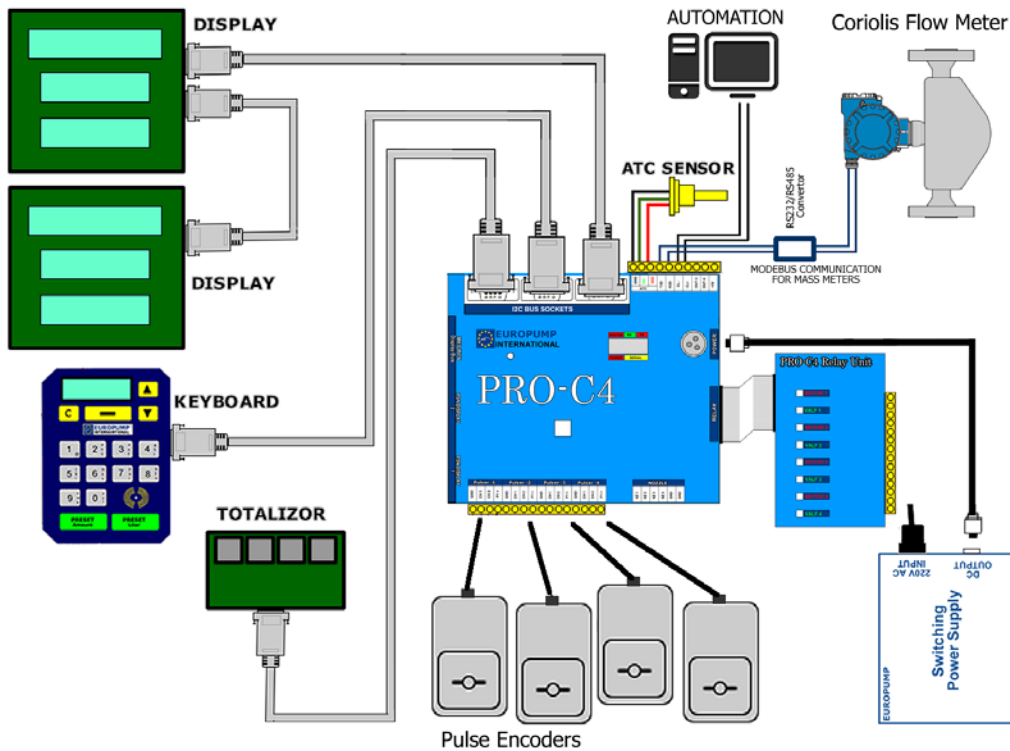

10.4. DESCRIPTION OF DISPLAYED ERRORS

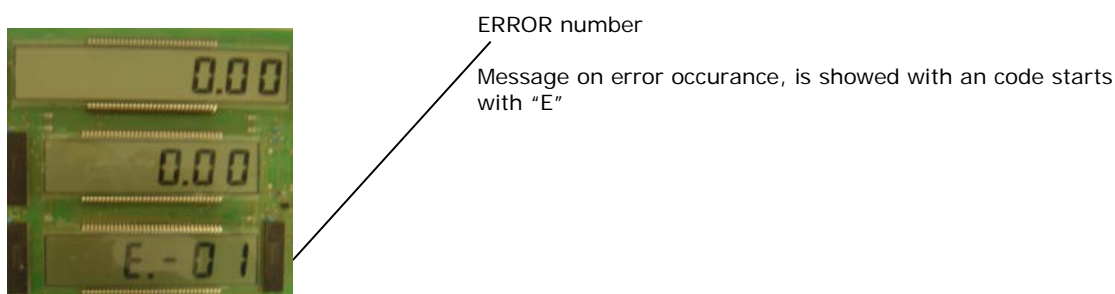

Item	Error No.	Error Description	Procedure in case of error occurrence
1	E-01	No electricity / Supply error	Check 220 Vac input voltage at supply unit. If no 220 Vac present, check fuse inside the dispenser. If on fuse no defect present, check respective fuses and mains at panel to supply dispenser. Eliminate defects encountered and operate the system. Check at panel cables to supply the dispenser . If in supply unit 220 Vac input voltage present, but 12 Vac output voltage not present means, a defect has occurred in supply unit. Eliminate the fault by replacing the supply unit. If 12 Vac output voltage in supply unit present means, a computer fault has occurred. Eliminate the fault by replacing the computer.
2	E-02	Supply protection fuse	A fault in computer may be present. Eliminate fault by replacing the computer (fuse F1 in computer defect)
3	E-17	No pulser current	Check voltage at ends P1 and GND of the computer' pulser input socket. If at these ends 5 Vds voltage present, pulser is defective. Eliminate defect by replacing the pulser. If no 5 Vdc voltage present means, computer is defective. Eliminate defect by replacing computer.
4	E-18	Pulser channel–A error	Check with oscilloscope in channel A of pulser for square wave signals. If in channel A no square wave signal present, then pulser is defective. Eliminate defect by replacing pulser. If in channel A of pulser square wave signal present,, then computer might be defective. Eliminate defect by replacing computer.
5	E-19	Pulser channel–B error	Check with oscilloscope in channel B of pulser for square wave signals. If in channel A no square wave signal present, then pulser is defective. Eliminate defect by replacing pulser. If in channel B of pulser square wave signal present, then computer might be defective. Eliminate defect by replacing computer.
9	E-26	Electromechanical totalisor error	Check electromechanical total connection. If there is no fault in connection, change electromechanical total.
10	E-29	Nozzle open (electricity cut off)	Place nozzle in boot. If error persists, check switch and if defective replace. If no defect on switch observed, check cables enabling communication between computer and switch. If cables not found to be defective, replace computer.
11	E-31	Unit price not entered	Entering the unit price, error can be eliminated.
12	E-36	Liter field beyond limit	If in system liter total limitation is set for each sale, the dispenser can not sell more than the set amount for every sale. If required, limitation can be cancelled by entering max. amo. value 0 (zero) from service menu.
13	E-37	Money field beyond limit	If in system sales amount limitation is set for each sale, the dispenser can not sell more than the set liters for every sale. If required, limitation can be cancelled by entering max. vol. value 0 (zero) from service menu.
14	E-39	Solenoid valve leakage	Error occurs, when in preset delivery mode, product delivery exceeds preset value. Check solenoid valves.
15	E-42	Service menu/W&M active	Temporary error code. Occures when lifting nozzle while in service menu or W&M switch is active. Insert nozzle back into boot, leave service menu, then lift nozzle.
16	E-43	WATCHDOG time expiry	Error in case of product delivery under value entered into computer. Eliminated by inserting nozzle back into nozzle boot.

11. TECHNICAL DATA

SPECIFICATION (Özellik)		Unit (Birim)	Type (Tip) E , T , F Series
Grades Yakıt Sayısı	Pcs		1
No of Nozzle Tabanca Sayısı	Pcs		1-2-4
Simultaneous Filings Aynı Anda Dolum	Pcs		1-2-4
Capacity Max. Max. Kapasite	(dm ³ /min)		50
Capacity Min. Min. Kapasite	(dm ³ /min)		5
Type of Display Display Tipi			Electronic
Maximum Unit Price (Digits) Max. Hane Sayısı			9999 9999 (8)
Maximum Price to Pay (Digits) Max. Tutar Hanesi			99 9999 9999 (10)
Scale Interval, Volume/Mass Disp. Ölçüm Hassasiyeti	Liter		0.01
Type of Liquid Likit Tipi			LPG
Mechanical Class Mekanik Sınıf			M2
Accuracy Class Hassasiyet Sınıfı			0.1
Electromagnetic Class Elektromanyetik Sınıf			E2
Accuracy Class Hassasiyet Sınıfı			0,5%-0,2%
Design pressure Tasarım Basıncı	BAR		25
Ambient temperature Ortam Sıcaklığı	(°C)		-20 ...+40
Relative Humidity Bağıl Nem	(%)		Condensing Yoğuşmalı
Supply Voltage Gerilim	(V)		230 – 400 ± 10%
Frequency Frekans	(Hz)		50
Hose Hortum	Meter		Between 4m and 6 m Maximum liquid content of 1,5 litres 4m ve 6m arası Maksimum sıvı içeriği 1,5 litre
Housing Kasa			Electroplated, Lacquered galvanise or stainless steel Elektrostatik boyalı galvaniz veya Paslanmaz
Amount /Volume Programming Tutar veya Hacim Programla			Money - Volume – Mass Para – Hacim – Kütle **
Location Open Yerleşim Yeri			OPEN AÇIK HAVA

Kinds of delivered products:

- propane-butane liquefied gas

12. BREAKDOWN REPAIRS

- Any repair shall be made by trained persons provided with proper competence.
- Before any activities are made inside the LPG dispenser the power master switch (motors, lighting, counter, etc.) , which is situated in the room of filling station personnel, shall be switched off.
- **Always cut off power supply by switching power master switch off.**

13. Overall Dimensions

- Eurostar E1-SL
- Eurostar E2-SL

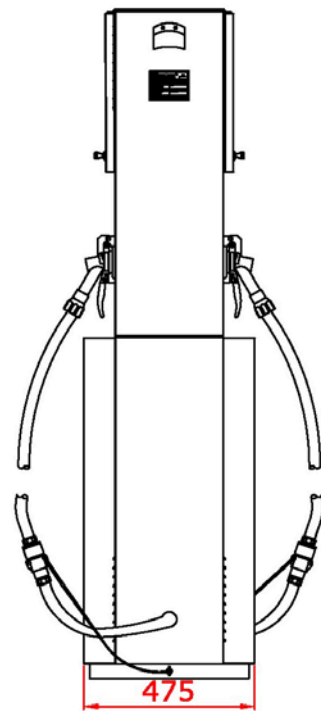
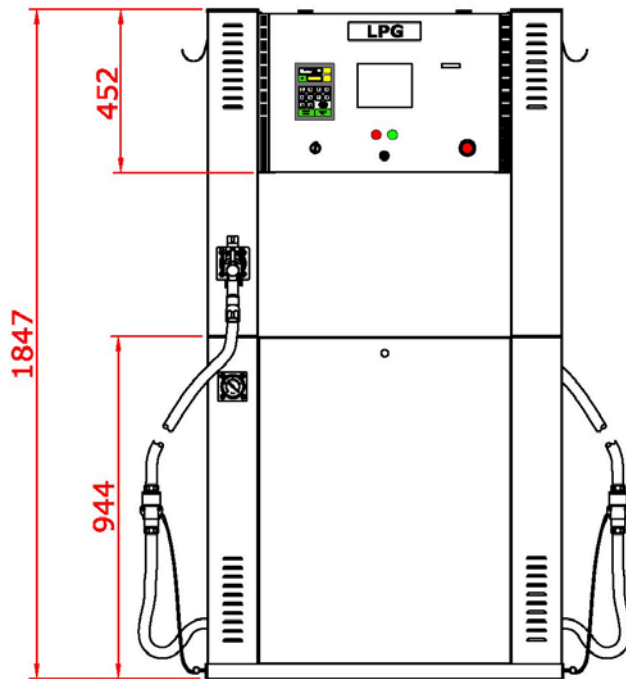

- Eurostar E1-SM

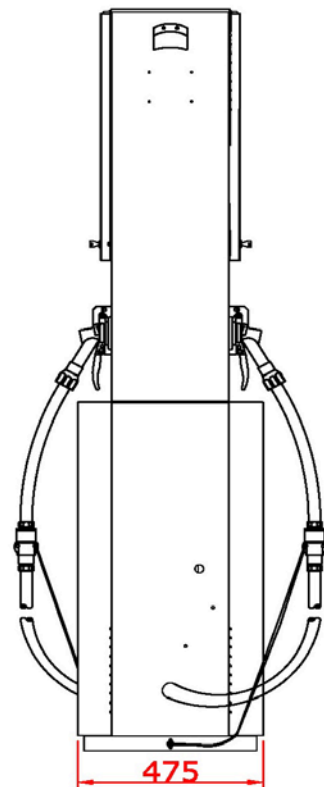
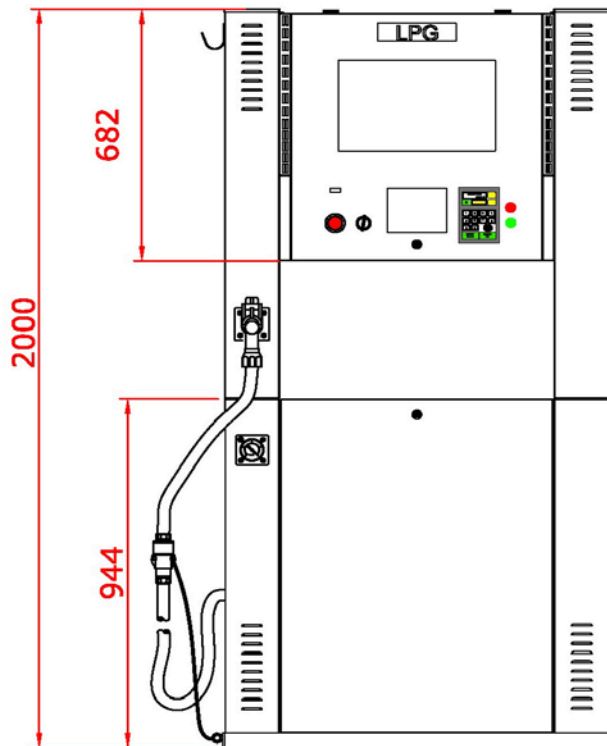

- Eurostar E2-SM

- Eurostar T1-SL
- Eurostar T2-SL

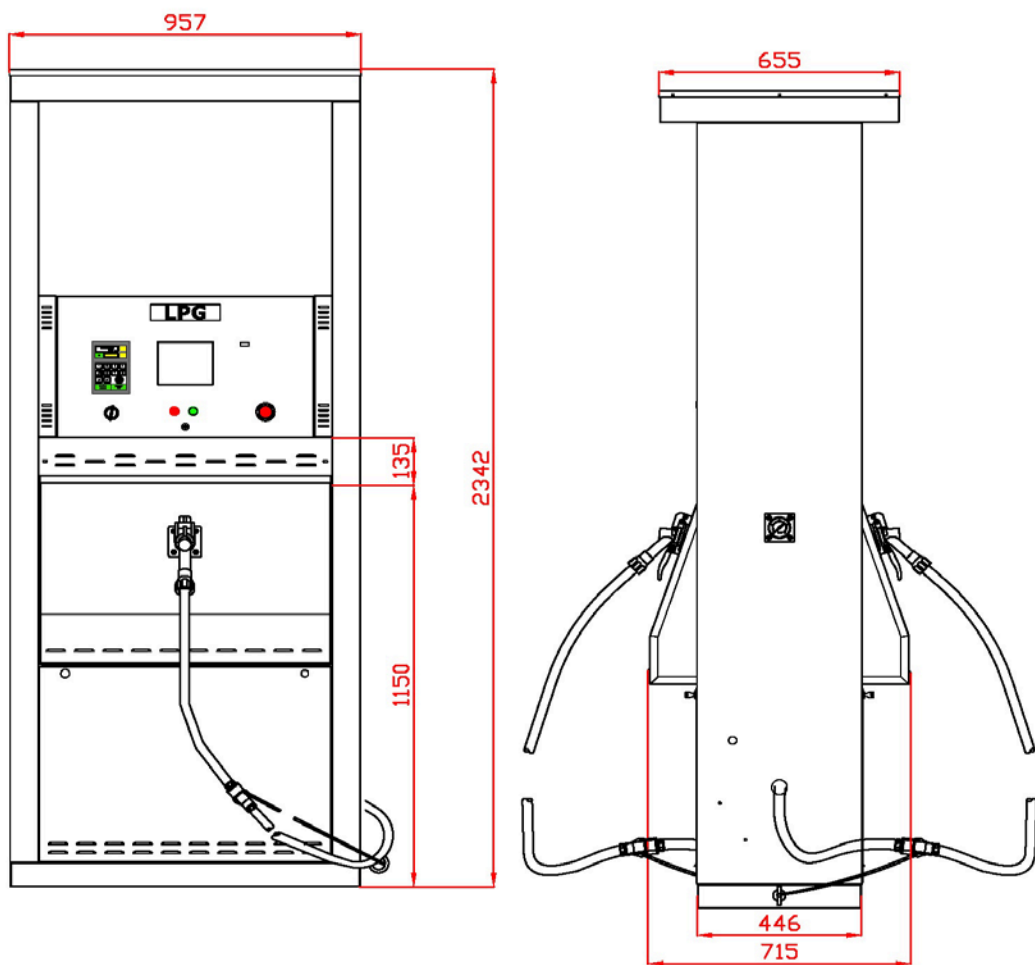

- Eurostar T1-SS
- Eurostar T2-SS

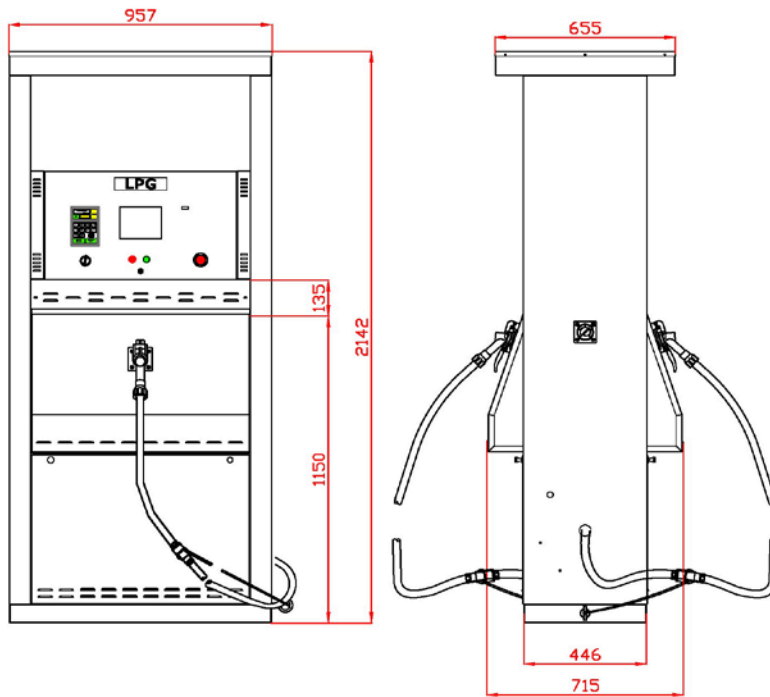

- Eurostar T1-ES
- Eurostar T2-ES

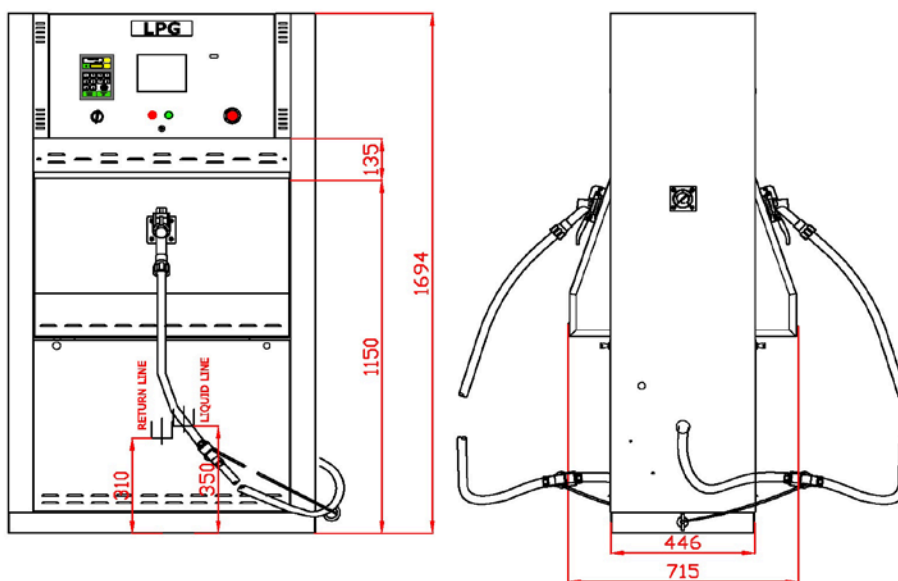

- Eurostar T1-XL
- Eurostar T2-XL

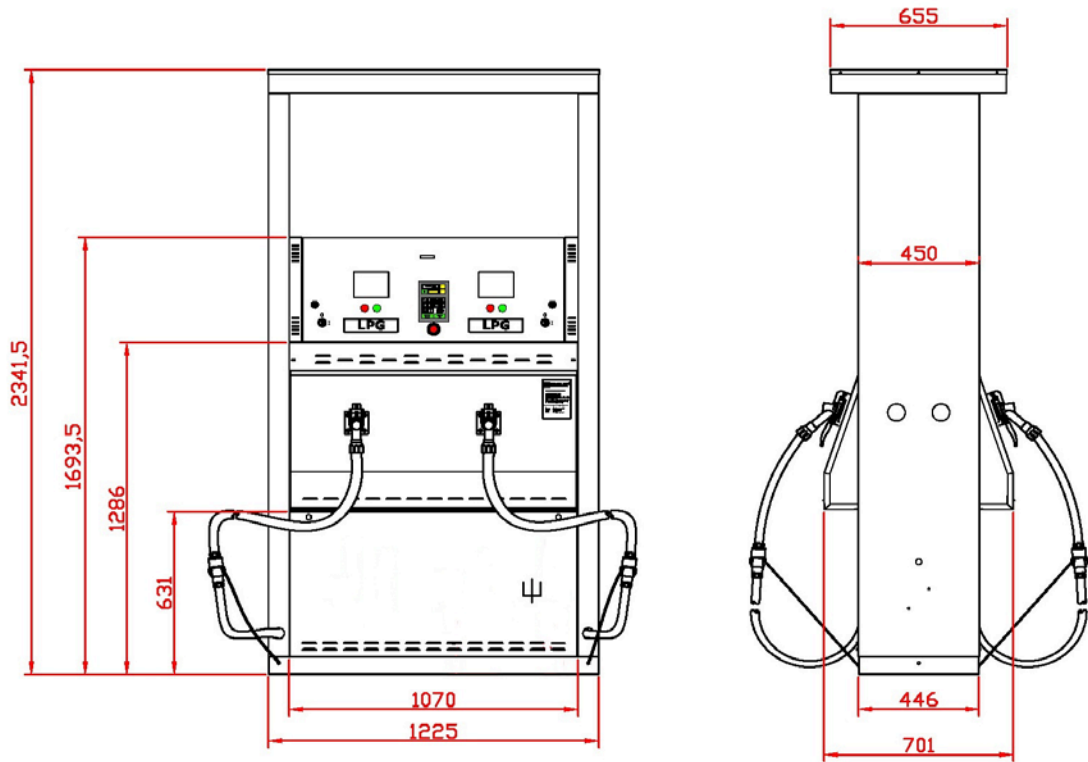

- Eurostar T4-XL
- Eurostar T1-XM
- Eurostar T2-XM
- Eurostar T4-XM

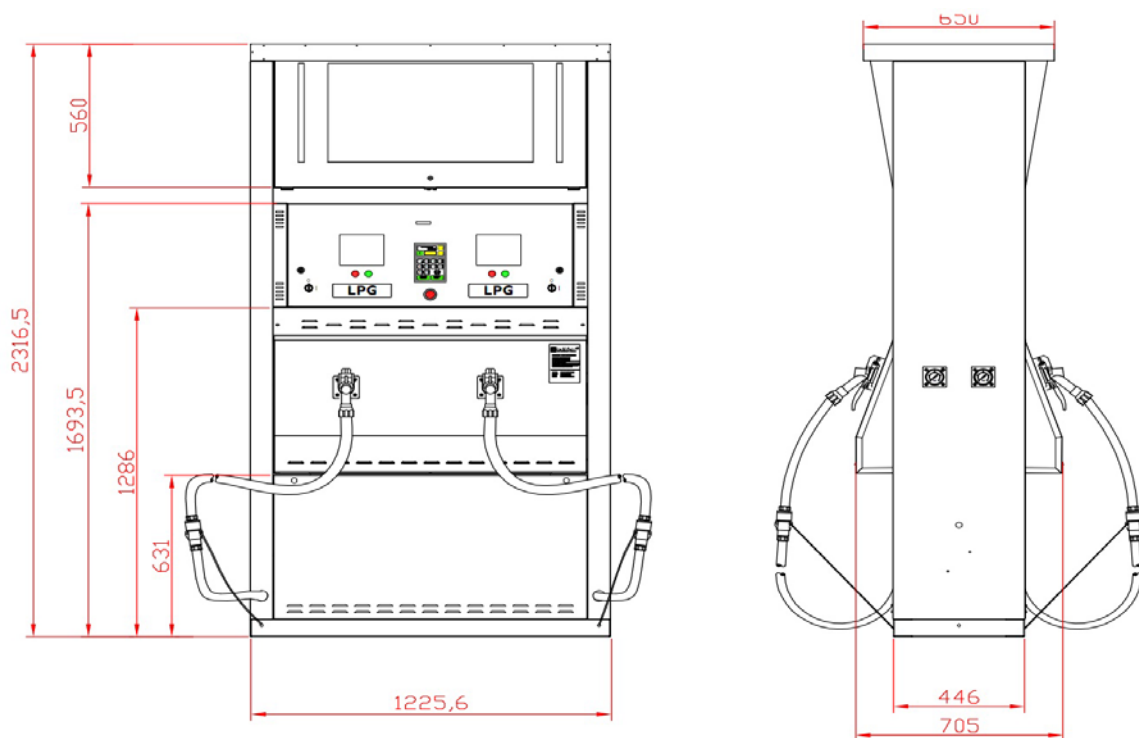

- Eurostar T1-XX
- Eurostar T2-XX
- Eurostar T4-XX

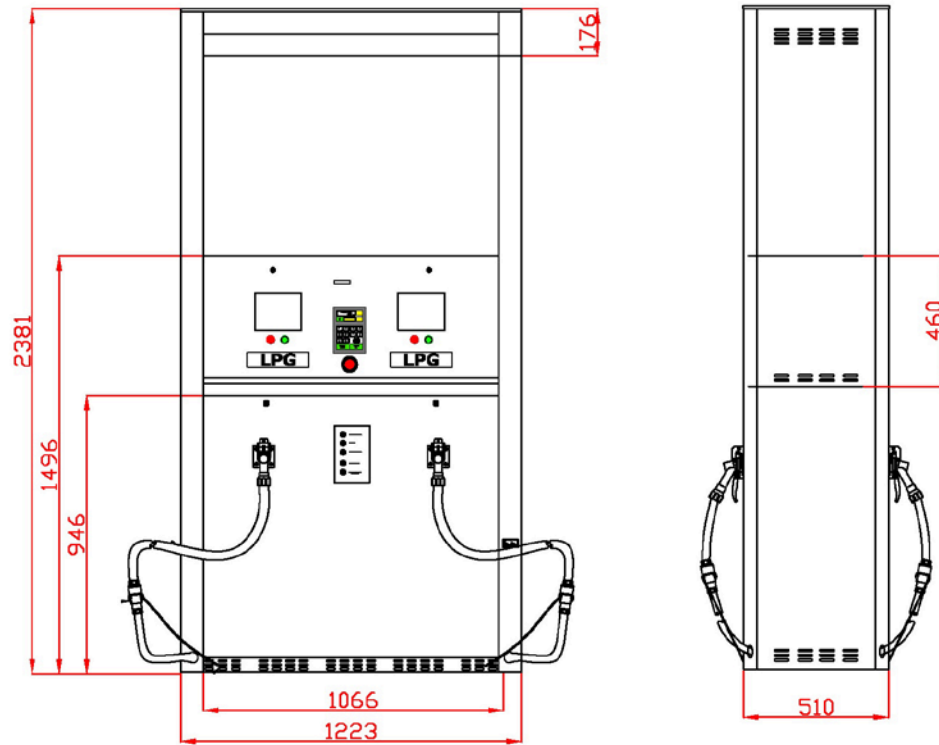

- Eurostar E1-FL
- Eurostar E2-FL

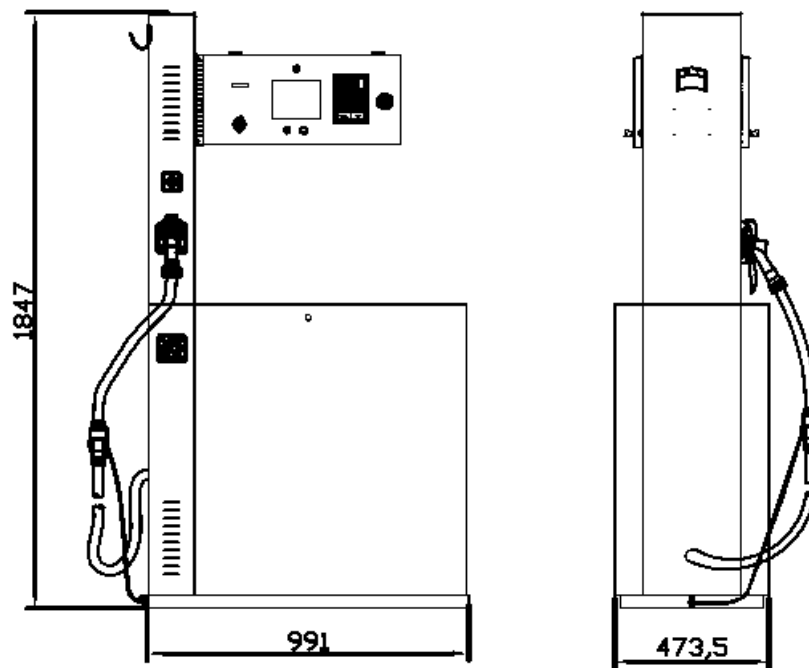

- Eurostar E1-MI
- Eurostar E2-MI

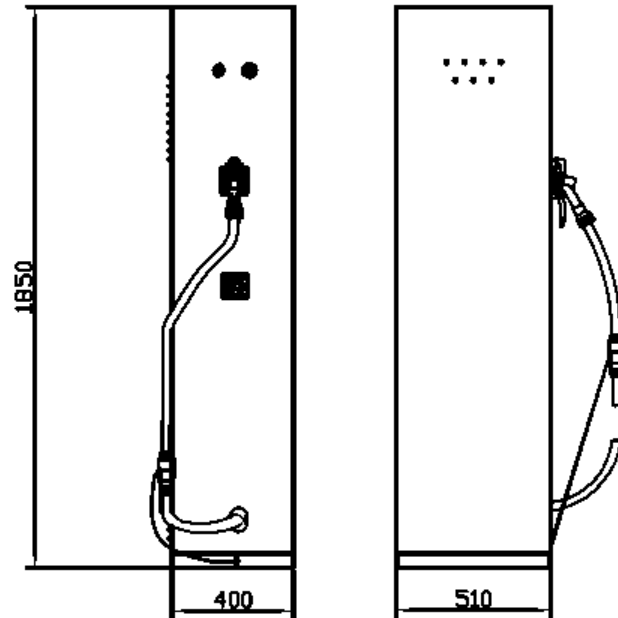

14. Classification of hazardous areas

NOTICE

- KEYBOARD, DISPLAY AND ELECTROMECHANIC TOTAL WINDOW SEALED WITH SILICONE PLACED IN ENCLOSURE
- "n" LETTERS REFERS NOZZLE NUMBERS

- Eurostar En-SL and En-SS

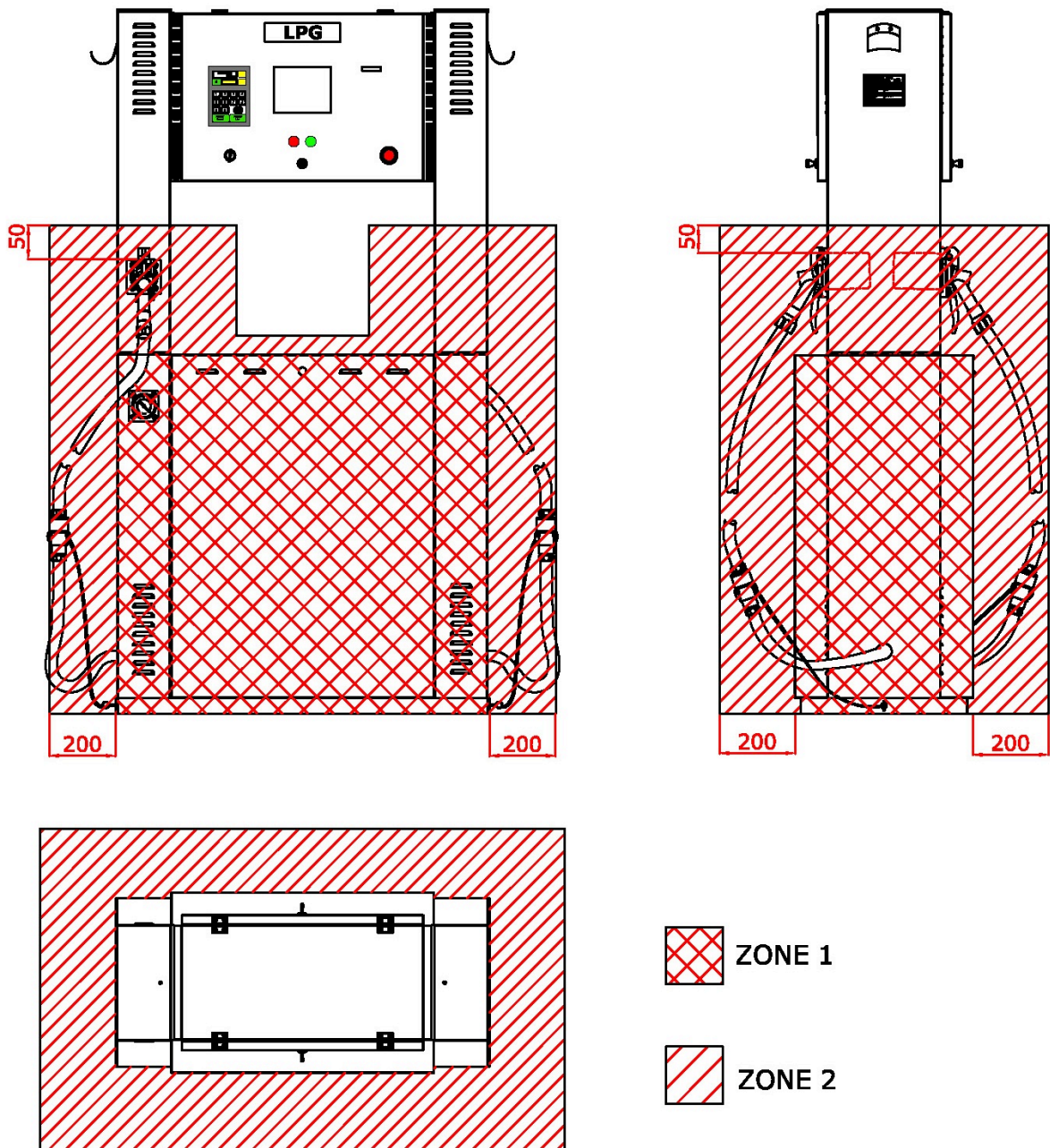

- Eurostar En-SM

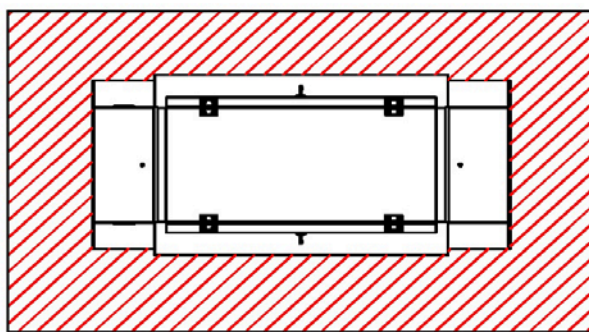
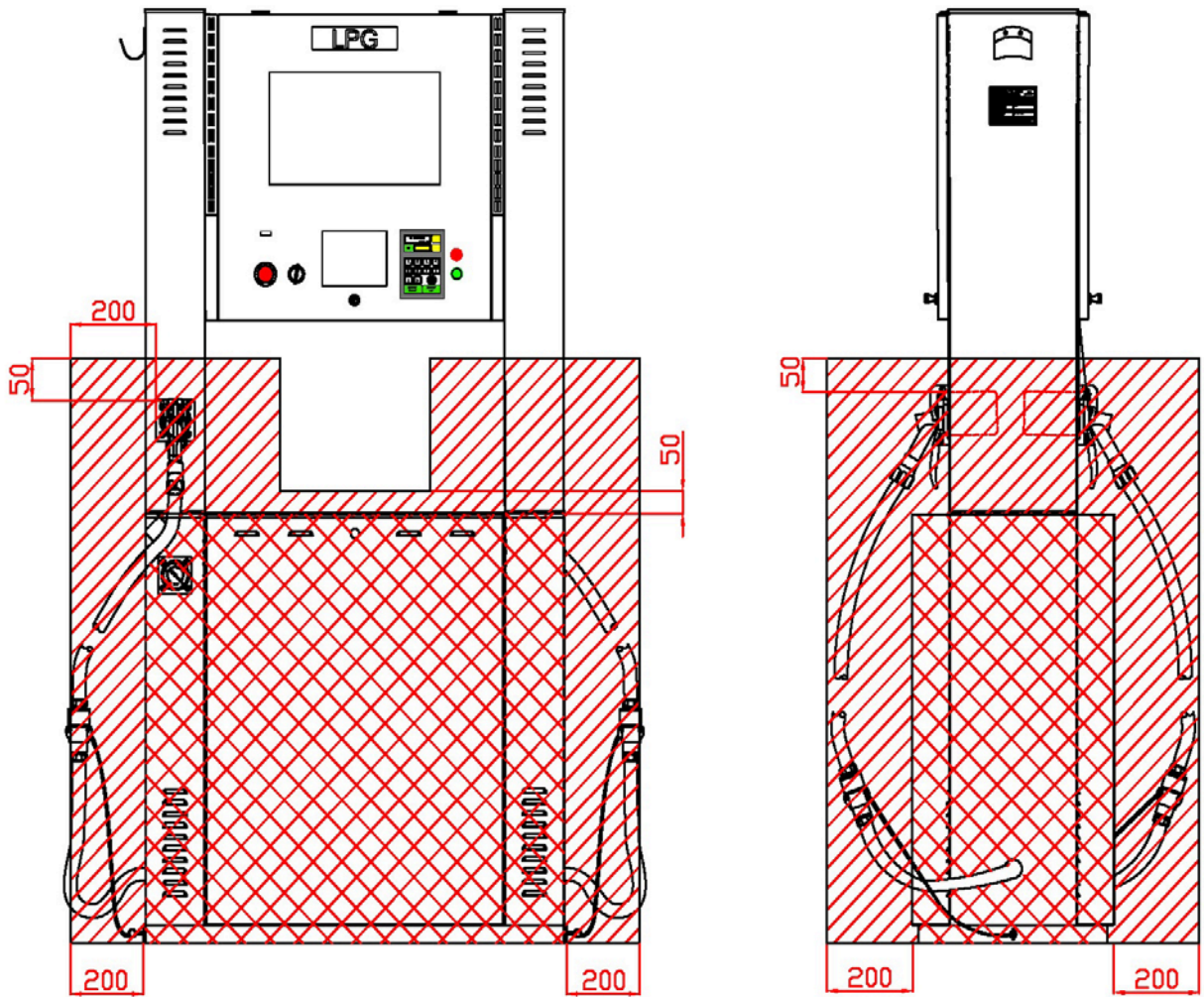

 ZONE 1

 ZONE 2

- Eurostar Tn-SL, Tn-SS, Tn-ES

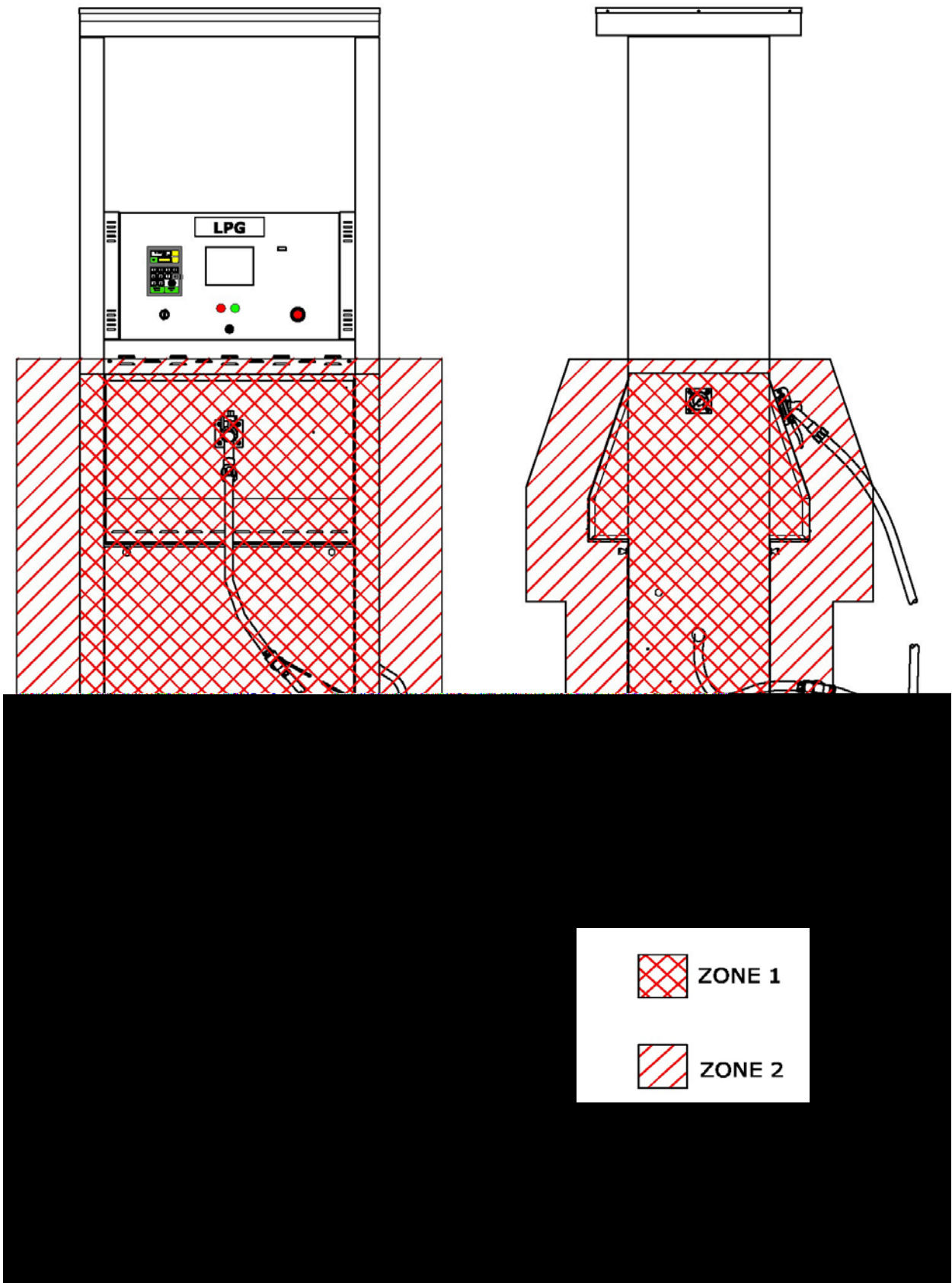

- Eurostar Tn-XL, Tn-XS, Tn-XM

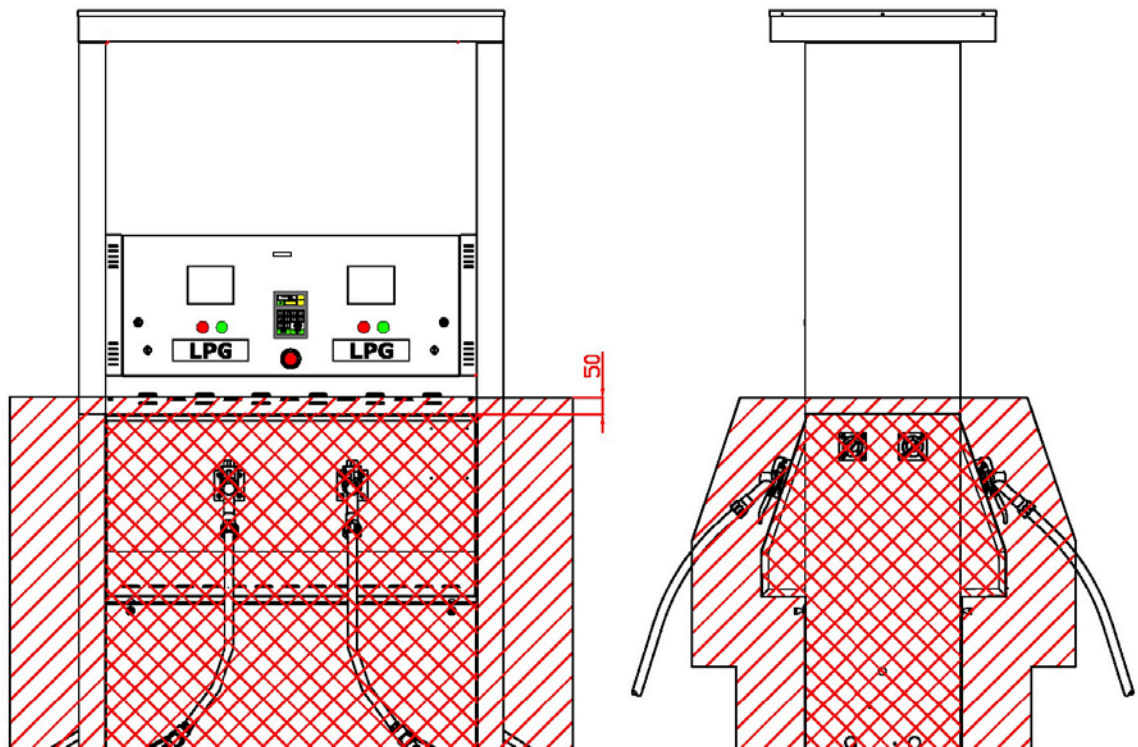

- Eurostar Tn-XX

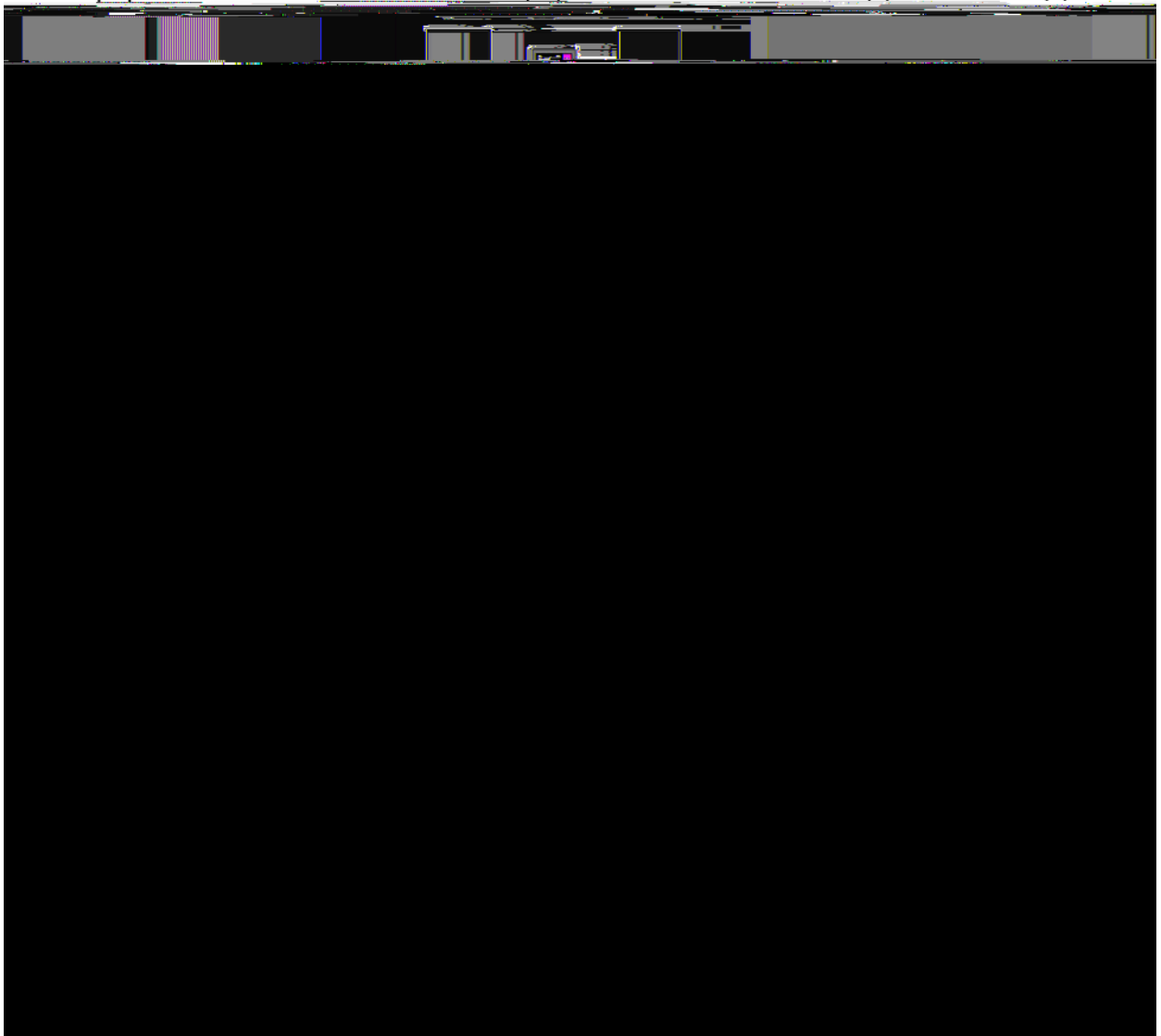
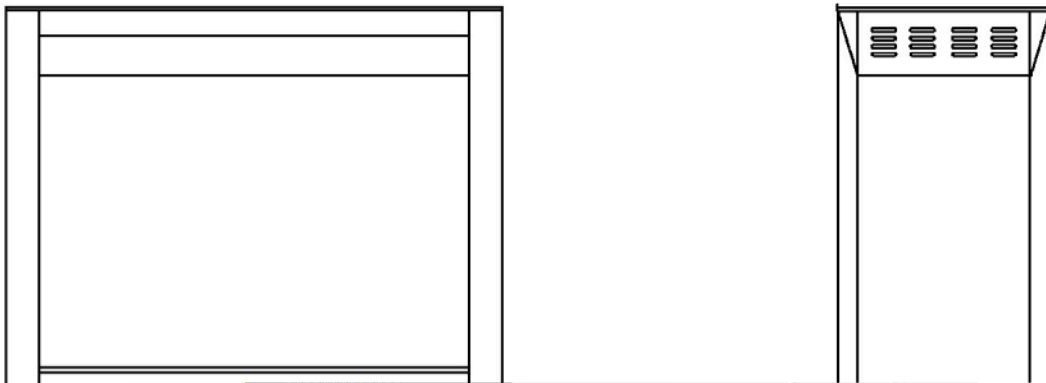

15. Electrical Connection Diagram

Connection diagram of the dispenser with the switchboard at the filling station

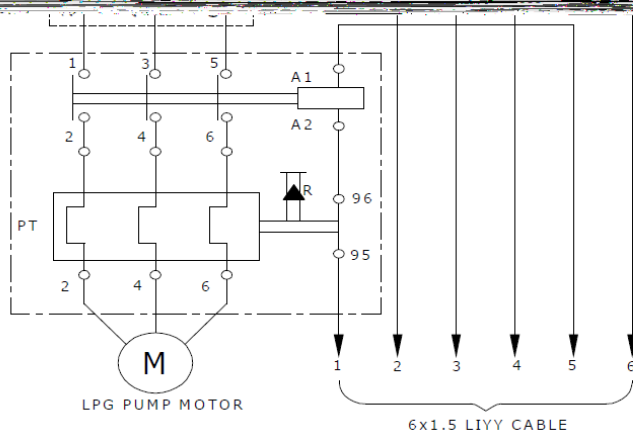

Description of signals:

- 1 - Control of motor pump
- 2 - Control of dispenser illumination
- 3 - Neutral
- 4 - Hose for dispenser
- 5 - Contact of breakdown switch
- 6 - Contact of breakdown switch

Junction box connection diagram of the Eurostar Dispensers

Single Nozzle

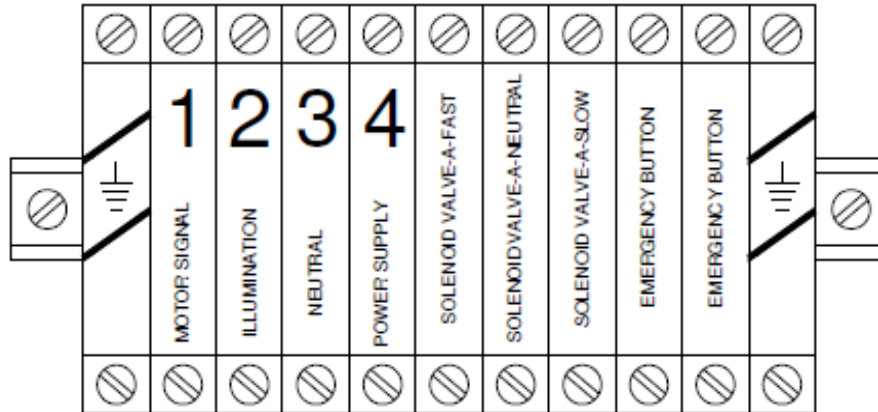

Multiple Nozzle



Hydraulic system connections of the LPG dispenser at the filling station

Notice : The responsibility of break off valves belongs to the customer.

- Connection of the liquefied phase in a LPG dispenser

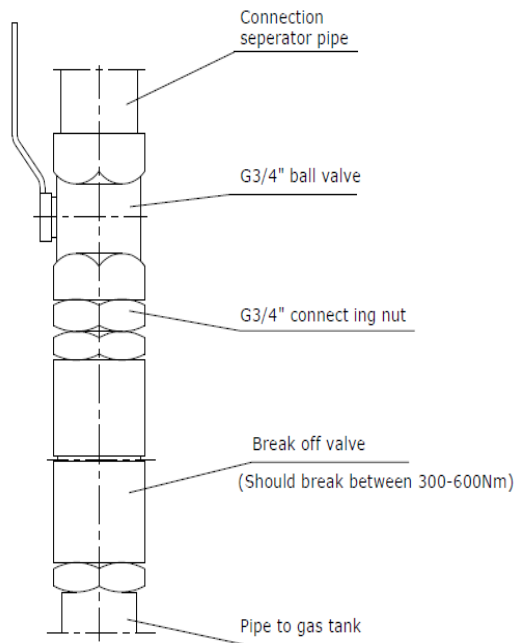

- Connection of the gaseous phase in a LPG dispenser

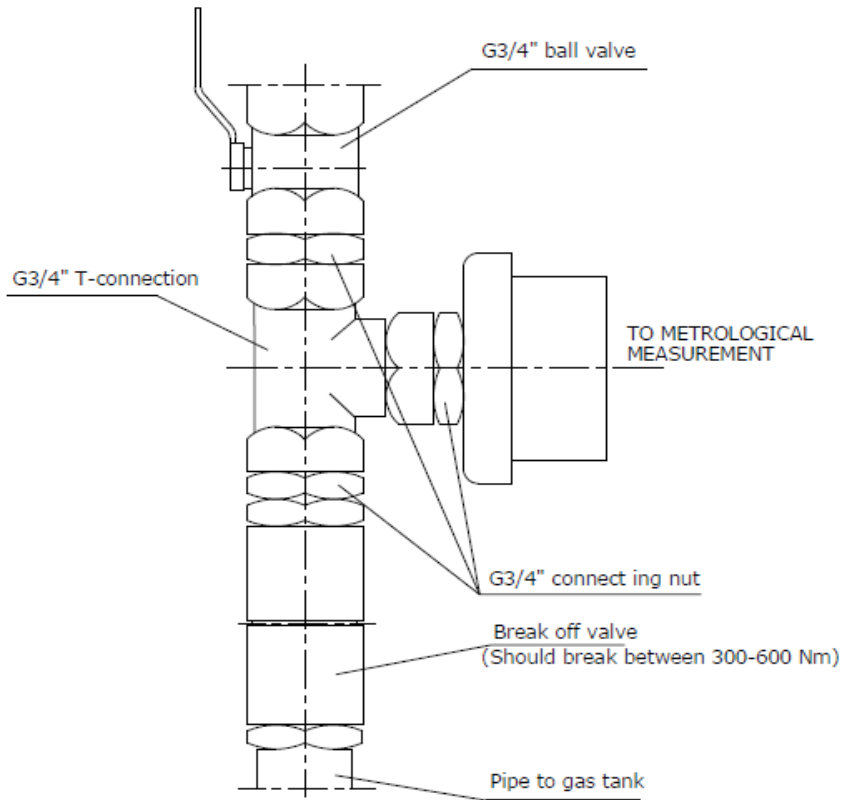

16. Hydraulic system diagram for LPG dispensers

LPG Dispensers with PD Meters

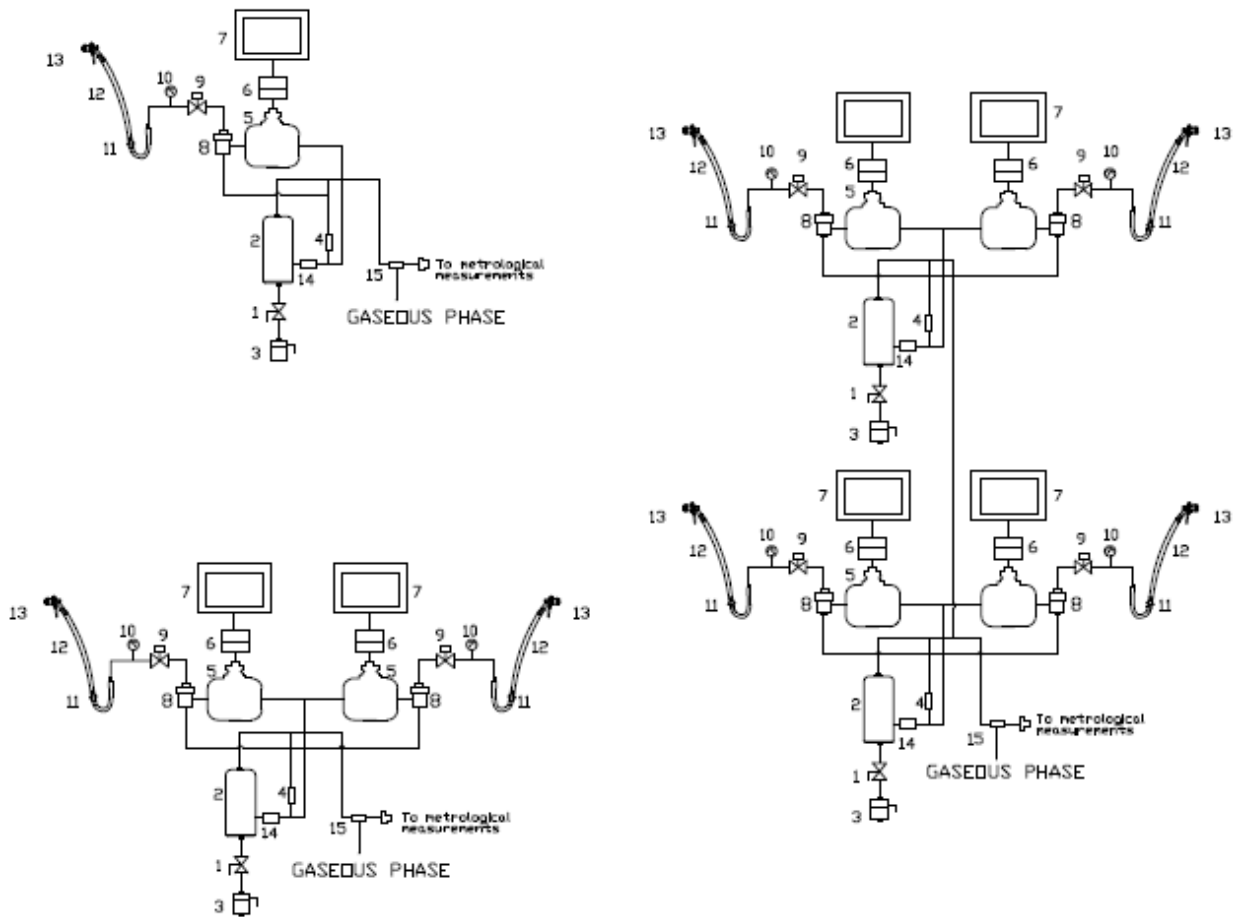

- | | |
|-----------------|-----------------------|
| 1. Ball valve | 8. Differential Valve |
| 2. Seperator | 9. Solenoid Valve |
| 3. Filter | 10. Manometer |
| 4. Relief valve | 11. Breakaway |
| 5. Meter | 12. Delivery Hose |
| 6. Pulsar | 13. Nozzle |
| 7. Display | 14. Checkvalve |
| | 15. Filling connector |

17. Foundation Diagram FOR LPG dispenser

Foundation of the LPG dispenser (Single Nozzle)

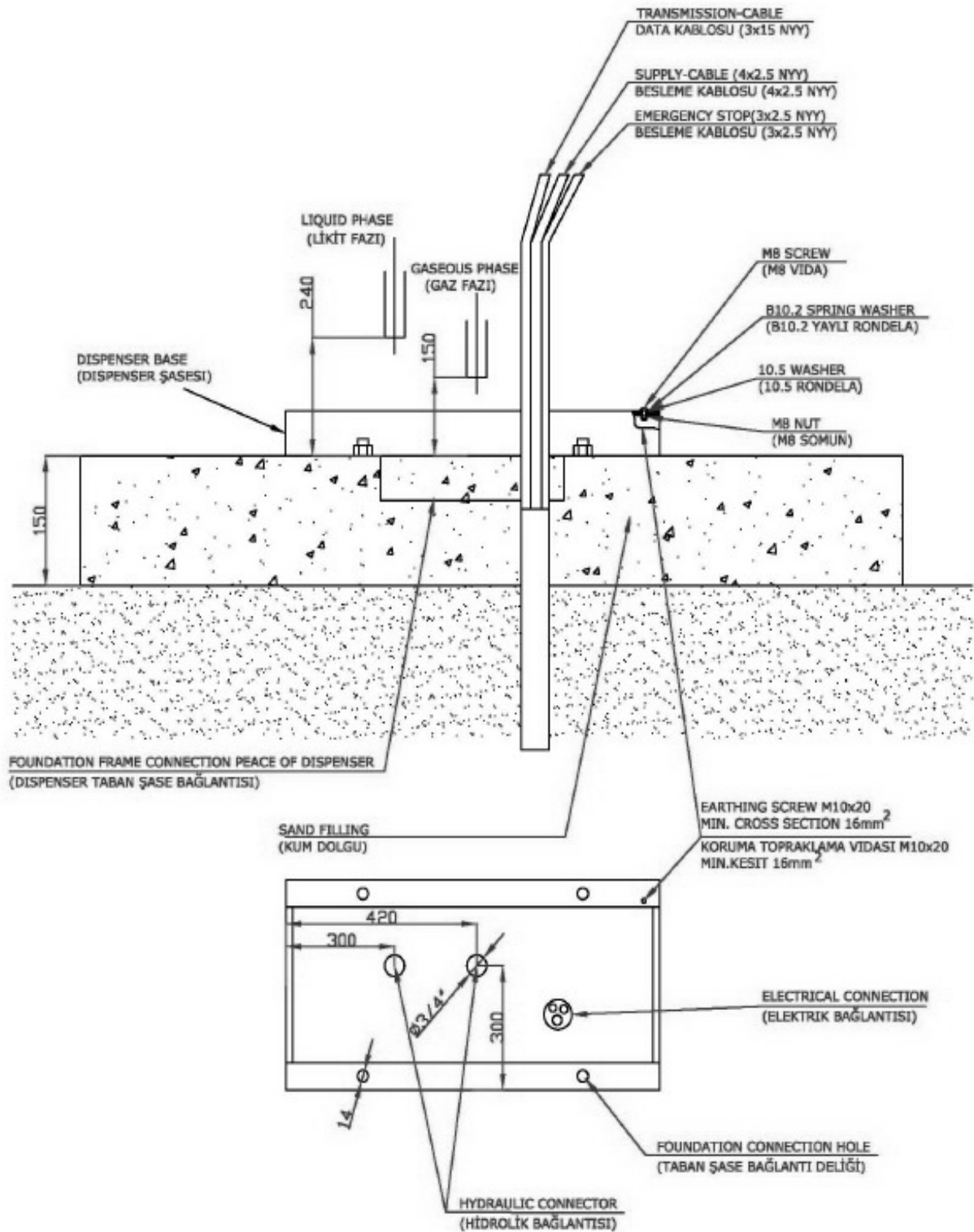

Foundation of the LPG dispenser (Multiple Nozzle)

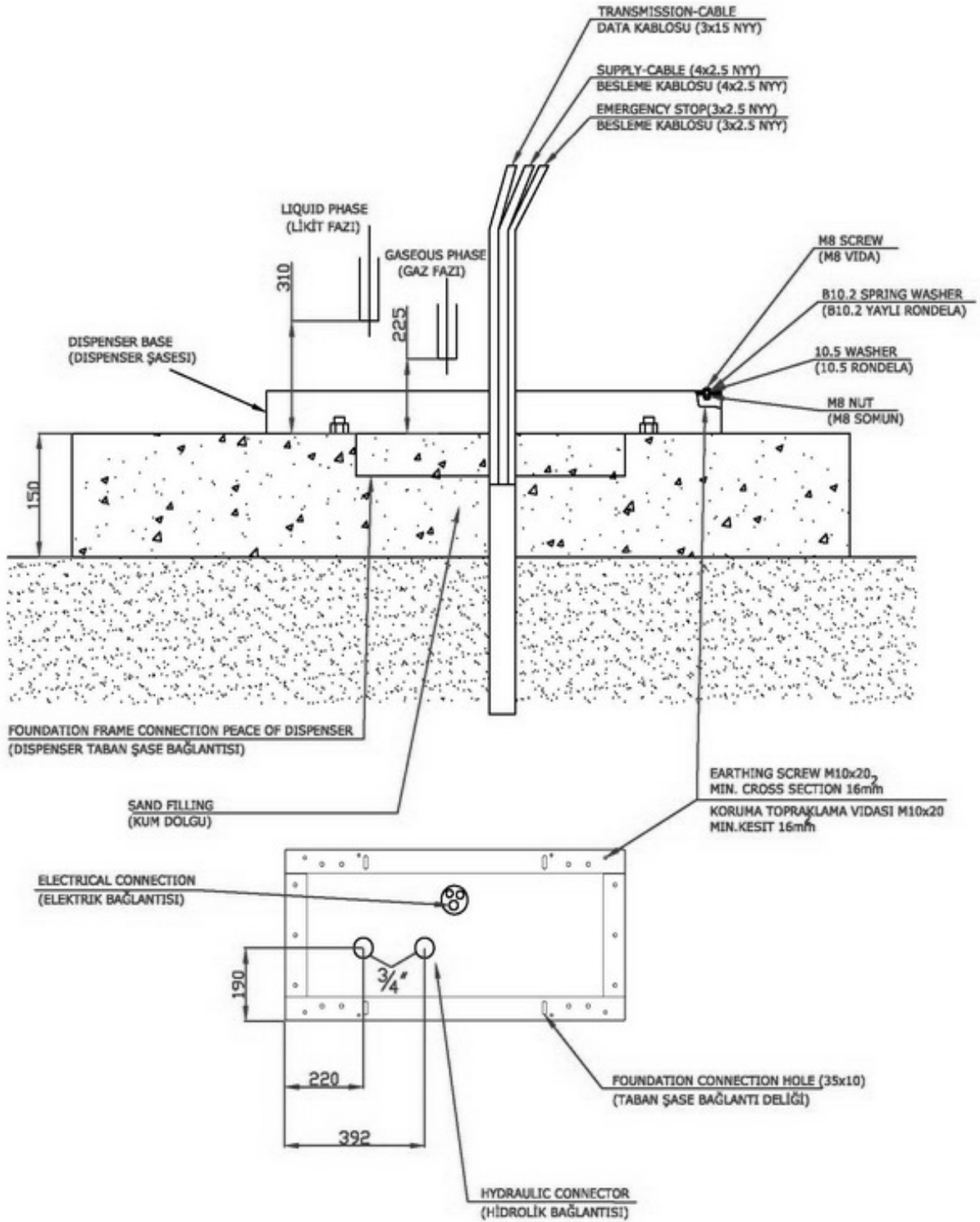

Foundation of the LPG dispenser (4 Nozzle)

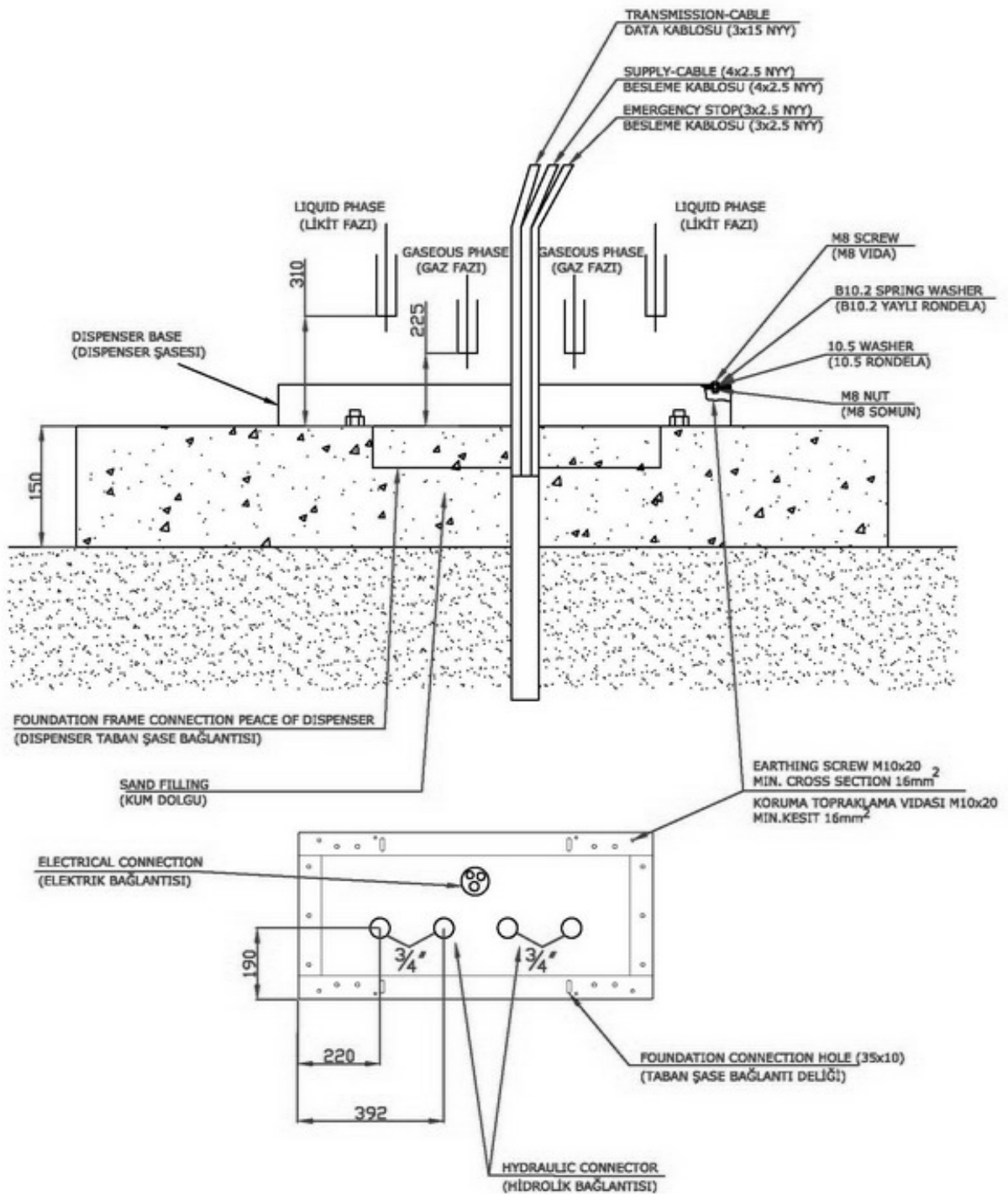
**Notice**

1. Connections of gaseous and liquefied phases are to be made very carefully according to the present service manual
2. Electric connection is to be made very carefully according to the present service manual
3. Connect the protection earthing of the dispenser to the M10x20 screw in the base.
4. Foundation frame is not included in the dispenser equipment
5. After hydraulic system and electrical connection to the dispenser are made, the hole in the distributor base is to be filled up with sand/as in the drawing below.

18. CONTACT US :

Please do not hesitate to contact us for your all kind of technical and sales support from our website www.europump.com or following worldwide offices :

ITALY :

Europump Italia SRL

Via Privata Georges Bizet, 36/G, 20092 Cinisello Balsamo MI ITALY

E-mail: italy@europump.com

Telephone: +39 02 612 99144 Fax: +39 02 407 05784

POLAND :

EUROPUMP POLSKA Spółka z o. o.

86-300 Grudziądz ul. Rapackiego 37 Poland

E-mail: poland@europump.com

Telephone: +48 56 64 11 666 Fax: +48 56 64 11 665

TURKEY :

Istanbul Mermerciler Sanayi Sitesi 18.Cad 22.Sok No:32

Koseler Koyu, 41480 Dilovasi/Kocaeli

E-mail: turkey@europump.com

Telephone: +90 216 365 35 70 Fax: +90 216 365 35 72